



Informatica® Data Archive  
6.5.1

# Installation and Upgrade Guide

© Copyright Informatica LLC 2003, 2021

This software and documentation contain proprietary information of Informatica LLC and are provided under a license agreement containing restrictions on use and disclosure and are also protected by copyright law. Reverse engineering of the software is prohibited. No part of this document may be reproduced or transmitted in any form, by any means (electronic, photocopying, recording or otherwise) without prior consent of Informatica LLC. This Software may be protected by U.S. and/or international Patents and other Patents Pending.

Use, duplication, or disclosure of the Software by the U.S. Government is subject to the restrictions set forth in the applicable software license agreement and as provided in DFARS 227.7202-1(a) and 227.7702-3(a) (1995), DFARS 252.227-7013(1)(ii) (OCT 1988), FAR 12.212(a) (1995), FAR 52.227-19, or FAR 52.227-14 (ALT III), as applicable.

The information in this product or documentation is subject to change without notice. If you find any problems in this product or documentation, please report them to us in writing.

Informatica, Informatica Platform, Informatica Data Services, PowerCenter, PowerCenterRT, PowerCenter Connect, PowerCenter Data Analyzer, PowerExchange, PowerMart, Metadata Manager, Informatica Data Quality, Informatica Data Explorer, Informatica B2B Data Transformation, Informatica B2B Data Exchange Informatica On Demand, Informatica Identity Resolution, Informatica Application Information Lifecycle Management, Informatica Complex Event Processing, Ultra Messaging, Informatica Master Data Management, and Live Data Map are trademarks or registered trademarks of Informatica LLC in the United States and in jurisdictions throughout the world. All other company and product names may be trade names or trademarks of their respective owners.

Portions of this software and/or documentation are subject to copyright held by third parties, including without limitation: Copyright DataDirect Technologies. All rights reserved. Copyright © Sun Microsystems. All rights reserved. Copyright © RSA Security Inc. All Rights Reserved. Copyright © Ordinal Technology Corp. All rights reserved. Copyright © Aandacht c.v. All rights reserved. Copyright Genivia, Inc. All rights reserved. Copyright Isomorphic Software. All rights reserved. Copyright © Meta Integration Technology, Inc. All rights reserved. Copyright © Intalio. All rights reserved. Copyright © Oracle. All rights reserved. Copyright © Adobe Systems Incorporated. All rights reserved. Copyright © DataArt, Inc. All rights reserved. Copyright © ComponentSource. All rights reserved. Copyright © Microsoft Corporation. All rights reserved. Copyright © Rogue Wave Software, Inc. All rights reserved. Copyright © Teradata Corporation. All rights reserved. Copyright © Yahoo! Inc. All rights reserved. Copyright © Glyph & Cog, LLC. All rights reserved. Copyright © Thinkmap, Inc. All rights reserved. Copyright © Clearpace Software Limited. All rights reserved. Copyright © Information Builders, Inc. All rights reserved. Copyright © OSS Nokalva, Inc. All rights reserved. Copyright Edifecs, Inc. All rights reserved. Copyright Cleo Communications, Inc. All rights reserved. Copyright © International Organization for Standardization 1986. All rights reserved. Copyright © ej-technologies GmbH. All rights reserved. Copyright © Jaspersoft Corporation. All rights reserved. Copyright © International Business Machines Corporation. All rights reserved. Copyright © yWorks GmbH. All rights reserved. Copyright © Lucent Technologies. All rights reserved. Copyright © University of Toronto. All rights reserved. Copyright © Daniel Veillard. All rights reserved. Copyright © Unicode, Inc. Copyright IBM Corp. All rights reserved. Copyright © MicroQuill Software Publishing, Inc. All rights reserved. Copyright © PassMark Software Pty Ltd. All rights reserved. Copyright © LogiXML, Inc. All rights reserved. Copyright © 2003-2010 Lorenzi Davide, All rights reserved. Copyright © Red Hat, Inc. All rights reserved. Copyright © The Board of Trustees of the Leland Stanford Junior University. All rights reserved. Copyright © EMC Corporation. All rights reserved. Copyright © Flexera Software. All rights reserved. Copyright © Jinfonet Software. All rights reserved. Copyright © Apple Inc. All rights reserved. Copyright © Telerik Inc. All rights reserved. Copyright © BEA Systems. All rights reserved. Copyright © PDFlib GmbH. All rights reserved. Copyright © Orientation in Objects GmbH. All rights reserved. Copyright © Tanuki Software, Ltd. All rights reserved. Copyright © Ricebridge. All rights reserved. Copyright © Sencha, Inc. All rights reserved. Copyright © Scalable Systems, Inc. All rights reserved. Copyright © jqWidgets. All rights reserved. Copyright © Tableau Software, Inc. All rights reserved. Copyright © MaxMind, Inc. All Rights Reserved. Copyright © TMate Software s.r.o. All rights reserved. Copyright © MapR Technologies Inc. All rights reserved. Copyright © Amazon Corporate LLC. All rights reserved. Copyright © Highsoft. All rights reserved. Copyright © Python Software Foundation. All rights reserved. Copyright © BeOpen.com. All rights reserved. Copyright © CNRI. All rights reserved.

This product includes software developed by the Apache Software Foundation (<http://www.apache.org/>), and/or other software which is licensed under various versions of the Apache License (the "License"). You may obtain a copy of these Licenses at <http://www.apache.org/licenses/>. Unless required by applicable law or agreed to in writing, software distributed under these Licenses is distributed on an "AS IS" BASIS, WITHOUT WARRANTIES OR CONDITIONS OF ANY KIND, either express or implied. See the Licenses for the specific language governing permissions and limitations under the Licenses.

This product includes software which was developed by Mozilla (<http://www.mozilla.org/>), software copyright The JBoss Group, LLC, all rights reserved; software copyright © 1999-2006 by Bruno Lowagie and Paulo Soares and other software which is licensed under various versions of the GNU Lesser General Public License Agreement, which may be found at <http://www.gnu.org/licenses/lgpl.html>. The materials are provided free of charge by Informatica, "as-is", without warranty of any kind, either express or implied, including but not limited to the implied warranties of merchantability and fitness for a particular purpose.

The product includes ACE(TM) and TAO(TM) software copyrighted by Douglas C. Schmidt and his research group at Washington University, University of California, Irvine, and Vanderbilt University, Copyright (©) 1993-2006, all rights reserved.

This product includes software developed by the OpenSSL Project for use in the OpenSSL Toolkit (copyright The OpenSSL Project. All Rights Reserved) and redistribution of this software is subject to terms available at <http://www.openssl.org> and <http://www.openssl.org/source/license.html>.

This product includes Curl software which is Copyright 1996-2013, Daniel Stenberg, <daniel@haxx.se>. All Rights Reserved. Permissions and limitations regarding this software are subject to terms available at <http://curl.haxx.se/docs/copyright.html>. Permission to use, copy, modify, and distribute this software for any purpose with or without fee is hereby granted, provided that the above copyright notice and this permission notice appear in all copies.

The product includes software copyright 2001-2005 (©) MetaStuff, Ltd. All Rights Reserved. Permissions and limitations regarding this software are subject to terms available at <http://www.dom4j.org/license.html>.

The product includes software copyright © 2004-2007, The Dojo Foundation. All Rights Reserved. Permissions and limitations regarding this software are subject to terms available at <http://dojotoolkit.org/license>.

This product includes ICU software which is copyright International Business Machines Corporation and others. All rights reserved. Permissions and limitations regarding this software are subject to terms available at <http://source.icu-project.org/repos/icu/icu/trunk/license.html>.

This product includes software copyright © 1996-2006 Per Bothner. All rights reserved. Your right to use such materials is set forth in the license which may be found at <http://www.gnu.org/software/kawa/Software-License.html>.

This product includes OSSP UUID software which is Copyright © 2002 Ralf S. Engelschall, Copyright © 2002 The OSSP Project Copyright © 2002 Cable & Wireless Deutschland. Permissions and limitations regarding this software are subject to terms available at <http://www.opensource.org/licenses/mit-license.php>.

This product includes software developed by Boost (<http://www.boost.org/>) or under the Boost software license. Permissions and limitations regarding this software are subject to terms available at [http://www.boost.org/LICENSE\\_1\\_0.txt](http://www.boost.org/LICENSE_1_0.txt).

This product includes software copyright © 1997-2007 University of Cambridge. Permissions and limitations regarding this software are subject to terms available at <http://www.pcre.org/license.txt>.

This product includes software copyright © 2007 The Eclipse Foundation. All Rights Reserved. Permissions and limitations regarding this software are subject to terms available at <http://www.eclipse.org/org/documents/epl-v10.php> and at <http://www.eclipse.org/org/documents/edl-v10.php>.

This product includes software licensed under the terms at <http://www.tcl.tk/software/tcltk/license.html>, <http://www.bosrup.com/web/overlib/?License>, <http://www.stlport.org/doc/license.html>, <http://asm.ow2.org/license.html>, <http://www.cryptix.org/LICENSE.TXT>, <http://hsqldb.org/web/hsqldbLicense.html>, <http://httpunit.sourceforge.net/doc/license.html>, <http://jung.sourceforge.net/license.txt>, [http://www.gzip.org/zlib/zlib\\_license.html](http://www.gzip.org/zlib/zlib_license.html), <http://www.openldap.org/software/release/license.html>, <http://www.libssh2.org>, <http://slf4j.org/license.html>, <http://www.sente.ch/software/OpenSourceLicense.html>, <http://fusesource.com/downloads/license-agreements/fuse-message-broker-v-5-3-license-agreement>; <http://antlr.org/license.html>; <http://aopalliance.sourceforge.net/>; <http://www.bouncycastle.org/licence.html>; <http://www.jgraph.com/jgraphdownload.html>; <http://www.jcraft.com/jsch/LICENSE.txt>; [http://jotm.objectweb.org/bsd\\_license.html](http://jotm.objectweb.org/bsd_license.html); <http://www.w3.org/Consortium/Legal/2002/copyright-software-20021231>; <http://www.slf4j.org/license.html>; <http://nanoxml.sourceforge.net/orig/copyright.html>; <http://www.json.org/license.html>; <http://forge.ow2.org/projects/javaservice/>; <http://www.postgresql.org/about/license.html>; <http://www.sqlite.org/copyright.html>; <http://www.tcl.tk/software/tcltk/license.html>; <http://www.jaxen.org/faq.html>; <http://www.jdom.org/docs/faq.html>; <http://www.slf4j.org/license.html>; <http://www.iodbc.org/dataspace/iodbc/wiki/IODBC/License>; <http://www.keplerproject.org/md5/license.html>; <http://www.toedter.com/en/jcalendar/license.html>; <http://www.edankert.com/bounce/index.html>; <http://www.net-snmp.org/about/license.html>; <http://www.openmdx.org/#FAQ>; [http://www.php.net/license/3\\_01.txt](http://www.php.net/license/3_01.txt); <http://srp.stanford.edu/license.txt>; <http://www.schneier.com/blowfish.html>; <http://www.jmock.org/license.html>; <http://xsom.java.net>; <http://benalman.com/about/license/>; <https://github.com/CreateJS/EaselJS/blob/master/src/easeljs/display/Bitmap.js>; <http://www.h2database.com/html/license.html#summary>; <http://jsoncpp.sourceforge.net/LICENSE>; <http://jdbc.postgresql.org/license.html>; <http://protobuf.googlecode.com/svn/trunk/src/google/protobuf/descriptor.proto>; <https://github.com/rantav/hector/blob/master/LICENSE>; <http://web.mit.edu/Kerberos/krb5-current/doc/mitK5license.html>; <http://jibx.sourceforge.net/jibx-license.html>; <https://github.com/lyokato/libgohash/blob/master/LICENSE>; <https://github.com/hjiang/jsonxx/blob/master/LICENSE>; <https://code.google.com/p/lz4/>; <https://github.com/jedisct1/libsodium/blob/master/LICENSE>; <http://one-jar.sourceforge.net/index.php?page=documents&file=license>; <https://github.com/EsotericSoftware/kryo/blob/master/license.txt>; <http://www.scala-lang.org/license.html>; <https://github.com/tinkerpop/blueprints/blob/master/LICENSE.txt>; <http://gee.cs.oswego.edu/dl/classes/EDU/oswego/cs/dl/util/concurrent/intro.html>; <https://aws.amazon.com/asl/>; <https://github.com/twbs/bootstrap/blob/master/LICENSE>; <https://sourceforge.net/p/xmlunit/code/HEAD/tree/trunk/LICENSE.txt>; <https://github.com/documentcloud/underscore-contrib/blob/master/LICENSE>, and <https://github.com/apache/hbase/blob/master/LICENSE.txt>.

This product includes software licensed under the Academic Free License (<http://www.opensource.org/licenses/afl-3.0.php>), the Common Development and Distribution License (<http://www.opensource.org/licenses/cddl1.php>), the Common Public License (<http://www.opensource.org/licenses/cpl1.0.php>), the Sun Binary Code License Agreement Supplemental License Terms, the BSD License (<http://www.opensource.org/licenses/bsd-license.php>), the new BSD License (<http://opensource.org/licenses/BSD-3-Clause>), the MIT License (<http://www.opensource.org/licenses/mit-license.php>), the Artistic License (<http://www.opensource.org/licenses/artistic-license-1.0>) and the Initial Developer's Public License Version 1.0 (<http://www.firebirdsql.org/en/initial-developer-s-public-license-version-1-0/>).

This product includes software copyright © 2003-2006 Joe Walnes, 2006-2007 XStream Committers. All rights reserved. Permissions and limitations regarding this software are subject to terms available at <http://xstream.codehaus.org/license.html>. This product includes software developed by the Indiana University Extreme! Lab. For further information please visit <http://www.extreme.indiana.edu/>.

This product includes software Copyright (c) 2013 Frank Balluffi and Markus Moeller. All rights reserved. Permissions and limitations regarding this software are subject to terms of the MIT license.

See patents at <https://www.informatica.com/legal/patents.html>.

DISCLAIMER: Informatica LLC provides this documentation "as is" without warranty of any kind, either express or implied, including, but not limited to, the implied warranties of noninfringement, merchantability, or use for a particular purpose. Informatica LLC does not warrant that this software or documentation is error free. The information provided in this software or documentation may include technical inaccuracies or typographical errors. The information in this software and documentation is subject to change at any time without notice.

#### NOTICES

This Informatica product (the "Software") includes certain drivers (the "DataDirect Drivers") from DataDirect Technologies, an operating company of Progress Software Corporation ("DataDirect") which are subject to the following terms and conditions:

1. THE DATADIRECT DRIVERS ARE PROVIDED "AS IS" WITHOUT WARRANTY OF ANY KIND, EITHER EXPRESSED OR IMPLIED, INCLUDING BUT NOT LIMITED TO, THE IMPLIED WARRANTIES OF MERCHANTABILITY, FITNESS FOR A PARTICULAR PURPOSE AND NON-INFRINGEMENT.
2. IN NO EVENT WILL DATADIRECT OR ITS THIRD PARTY SUPPLIERS BE LIABLE TO THE END-USER CUSTOMER FOR ANY DIRECT, INDIRECT, INCIDENTAL, SPECIAL, CONSEQUENTIAL OR OTHER DAMAGES ARISING OUT OF THE USE OF THE ODBC DRIVERS, WHETHER OR NOT INFORMED OF THE POSSIBILITIES OF DAMAGES IN ADVANCE. THESE LIMITATIONS APPLY TO ALL CAUSES OF ACTION, INCLUDING, WITHOUT LIMITATION, BREACH OF CONTRACT, BREACH OF WARRANTY, NEGLIGENCE, STRICT LIABILITY, MISREPRESENTATION AND OTHER TORTS.

Publication Date: 2021-12-21

# Table of Contents

<b>Preface .....</b>	<b>10</b>
Informatica Resources. . . . .	10
Informatica Network. . . . .	10
Informatica Knowledge Base. . . . .	10
Informatica Documentation. . . . .	10
Informatica Product Availability Matrices. . . . .	11
Informatica Velocity. . . . .	11
Informatica Marketplace. . . . .	11
Informatica Global Customer Support. . . . .	11
<b>Chapter 1: Installation Overview.....</b>	<b>12</b>
Introduction. . . . .	12
Data Archive Installation. . . . .	13
Data Vault Installation. . . . .	13
Component Selection. . . . .	14
Archive to Database. . . . .	14
Archive to Database or Data Vault. . . . .	14
Queries and Reports on Archived Data. . . . .	14
Application Accelerator Installation. . . . .	15
Dynamic Data Masking Installation. . . . .	15
Enabling Dynamic Data Masking. . . . .	15
<b>Chapter 2: Before You Install.....</b>	<b>17</b>
License Key. . . . .	17
X Window Server . . . . .	17
Data Archive Requirements for the ILM Repository. . . . .	17
ILM Repository User. . . . .	19
Data Archive Requirements for the ILM Engine. . . . .	20
System User Account. . . . .	20
System Requirements. . . . .	20
Port Availability. . . . .	20
Java Requirements. . . . .	20
Database Client. . . . .	21
Data Vault Requirements. . . . .	21
System User Account. . . . .	21
System Requirements. . . . .	21
Java Requirements. . . . .	22
Curl Requirements. . . . .	22
Visual C++ . . . . .	23
Port Number Requirements. . . . .	23

Data Vault Space Requirements. . . . .	23
<b>Chapter 3: Data Archive Installation. . . . .</b>	<b>24</b>
Data Archive Installation Overview. . . . .	24
Installation Package. . . . .	25
Installing Data Archive Components. . . . .	25
Graphical Mode Installation. . . . .	25
Installing the ILM Engine and Repository. . . . .	26
Installing Data Visualization. . . . .	30
Installing Data Vault Loader and Data Discovery. . . . .	30
Installing Data Vault Service for External Attachments. . . . .	32
Applying a HotFix. . . . .	33
Console Mode Installation. . . . .	33
Silent Mode Installation. . . . .	38
Silent Mode Installation Properties. . . . .	38
Installing in Silent Mode. . . . .	42
<b>Chapter 4: Data Vault Installation. . . . .</b>	<b>43</b>
Data Vault Installation Overview. . . . .	43
Graphical Mode Installation. . . . .	43
Installing the Data Vault Service in Graphical Mode. . . . .	43
Installing the Data Vault Agent in Graphical Mode. . . . .	47
Installing the Data Vault ODBC Driver in Graphical Mode. . . . .	49
Installing the Data Vault Data Archive Plug-in in Graphical Mode. . . . .	50
Installing the Data Vault Administration Tool and SQL Tool in Graphical Mode. . . . .	50
Console Mode Installation. . . . .	51
Installing the Data Vault Service in Console Mode. . . . .	51
Installing the Data Vault Agent in Console Mode. . . . .	54
Installing the Data Vault ODBC Driver in Console Mode. . . . .	55
Installing the Data Vault Data Archive Plug-in in Console Mode. . . . .	56
Silent Mode Installation. . . . .	57
Step 1. Create the Properties File. . . . .	57
Step 2. Run the Silent Installer. . . . .	62
<b>Chapter 5: Application Accelerator Installation. . . . .</b>	<b>63</b>
Application Accelerator Installation Overview. . . . .	63
Installing the Application Accelerators in Graphical Mode. . . . .	64
Installing the Application Accelerators in Console Mode. . . . .	65
<b>Chapter 6: Application Retirement for Healthcare Accelerator Installation. . . . .</b>	<b>66</b>
Application Retirement for Healthcare Accelerator Installation Overview. . . . .	66
Prerequisites. . . . .	66
Installing the Accelerator in Graphical Mode. . . . .	67

Installing the Accelerator in Console Mode. . . . .	68
After You Install. . . . .	68
<b>Chapter 7: MongoDB Accelerator Installation . . . . .</b>	<b>69</b>
MongoDB Accelerator Installation Overview. . . . .	69
Installing the MongoDB Accelerator in Graphical Mode. . . . .	70
Installing the MongoDB Accelerator in Console Mode. . . . .	70
After You Install. . . . .	71
<b>Chapter 8: Salesforce Accelerator Installation. . . . .</b>	<b>72</b>
Salesforce Accelerator Installation Overview. . . . .	72
Installing the Accelerator in Graphical Mode. . . . .	73
Installing the Accelerator in Console Mode. . . . .	73
After You Install. . . . .	74
<b>Chapter 9: After You Install. . . . .</b>	<b>75</b>
Client Machine Requirements. . . . .	75
Starting the ILM Application Server. . . . .	76
Logging In to Data Archive. . . . .	76
Starting the Data Vault Components. . . . .	76
Before You Start the Data Vault Components. . . . .	76
ssa_starter Syntax. . . . .	77
Startup Configuration Parameters. . . . .	77
Starting the Data Vault Service. . . . .	79
Starting the Data Vault Agent. . . . .	79
Configuring Memory Settings on a 64-bit Computer. . . . .	80
Configuring Embedded Tomcat for HTTPS. . . . .	80
Registering Services as Windows Services. . . . .	81
Registering the Archive Service. . . . .	81
Registering the Data Vault Service for External Attachments. . . . .	81
Configuring Data Archive. . . . .	82
Setting up SAP Retirement. . . . .	82
<b>Chapter 10: Data Archive Upgrade. . . . .</b>	<b>83</b>
Data Archive Upgrade Overview. . . . .	83
Before You Upgrade. . . . .	84
Upgrading Data Archive in Graphical Mode. . . . .	84
Upgrading Data Archive in Console Mode. . . . .	85
Upgrading Data Archive in Silent Mode. . . . .	86
After You Upgrade Data Archive. . . . .	86
Reverting to a Previous Version. . . . .	87

<b>Chapter 11: Data Vault Upgrade.....</b>	<b>88</b>
Data Vault Upgrade Overview. . . . .	88
Before You Upgrade a Data Vault Component. . . . .	89
Upgrading in Graphical Mode . . . . .	90
Upgrading in Console Mode. . . . .	91
Upgrading in Silent Mode. . . . .	91
Step 1. Create the Properties File. . . . .	92
Step 2. Run the Silent Installer. . . . .	92
Troubleshooting Data Vault Upgrade. . . . .	93
After You Upgrade. . . . .	93
Reverting an Upgrade. . . . .	95
<b>Chapter 12: ILM Data Validation Option Setup.....</b>	<b>96</b>
ILM Data Validation Option Setup Overview. . . . .	96
Before You Set Up the ILM Data Validation Option. . . . .	96
Install the Data Vault Service ODBC Driver. . . . .	97
Installing the Data Vault ODBC Driver in Graphical Mode. . . . .	97
Installing the Data Vault ODBC Driver in Console Mode. . . . .	98
Create a Data Vault Service ODBC Data Source. . . . .	99
Creating an ODBC Data Source on Windows. . . . .	99
Creating an ODBC Data Source on UNIX. . . . .	100
Create a PowerCenter Connection Object. . . . .	103
After You Set Up the ILM Data Validation Option. . . . .	103
<b>Chapter 13: Data Archive Source and Target Database Requirements.....</b>	<b>104</b>
Source Database Requirements. . . . .	104
Live Archiving. . . . .	105
Oracle Partition Exchange Purging. . . . .	105
SAP Application Retirement. . . . .	105
Target Database Requirements. . . . .	106
<b>Chapter 14: Data Archive Connectivity.....</b>	<b>107</b>
Data Archive Connectivity Overview. . . . .	107
Native Connectivity. . . . .	107
DataDirect Connect JDBC Connectivity. . . . .	108
PowerExchange Connectivity. . . . .	108
Third-Party JDBC Connectivity. . . . .	109
<b>Chapter 15: Data Archive Uninstallation.....</b>	<b>110</b>
Data Archive Uninstallation Overview. . . . .	110
Restore Archived Data. . . . .	110
Dropping Database Users and Links. . . . .	111

Dropping the ILM Repository. . . . .	111
Deleting the ILM Application Server Directory. . . . .	111
Uninstalling the Data Vault. . . . .	111
Uninstalling Source Adapters. . . . .	112
Deleting Remaining ILM Files. . . . .	112

## **Chapter 16: SAP Application Retirement..... 113**

SAP Application Retirement Overview. . . . .	113
SAP Application Retirement Architecture Options. . . . .	113
Setting Up SAP Application Retirement. . . . .	115
Step 1. Install the SAP Java Connector. . . . .	116
Step 2. Apply the SAP Transports. . . . .	116
Step 3. Assign Roles. . . . .	117
Step 4. Configure Conf.Properties. . . . .	117
Step 5: Set up the FTP or NFS Connection. . . . .	117
Creating the FTP Connection. . . . .	117
Creating the NFS Mount. . . . .	119

## **Appendix A: Database Users and Privileges..... 121**

Database Users and Privileges Overview. . . . .	121
Administration User. . . . .	121
Production Application User. . . . .	123
Staging User. . . . .	123
History Read-Only User. . . . .	125
History Application User. . . . .	125
Combined User and Archive User for Seamless Access. . . . .	126
IBM DB2 Privileges. . . . .	127
Bind Packages Privileges. . . . .	127
Login User Privileges. . . . .	128
SAP Application Retirement Privileges. . . . .	129
ZINFA_RETIREMENT_PREPARATION Role. . . . .	130

## **Appendix B: Data Visualization Designer Installation..... 132**

Data Visualization Designer System Requirements. . . . .	132
Installing Data Visualization Designer. . . . .	132

## **Appendix C: Data Archive Installation Requirements Checklist and Architecture Options..... 134**

Pre-Installation Requirements Overview. . . . .	134
Archive to a Database Checklists. . . . .	135
Data Archive Installer Prerequisites. . . . .	135
ILM Repository Requirements Checklist. . . . .	136
ILM Engine Requirements. . . . .	137



Client Machine Requirements. . . . .	138
ILM Discovery Option. . . . .	138
Archive or Retire to Data Vault Checklists. . . . .	138
Data Archive Installer Prerequisites. . . . .	139
ILM Repository Requirements Checklist. . . . .	140
ILM Engine Requirements. . . . .	141
Data Vault Requirements. . . . .	142
Client Machine Requirements. . . . .	144
Data Validation Option. . . . .	145
ILM Discovery Option. . . . .	145
Data Archive Options Installation Checklist. . . . .	146
SAP Retirement Installation Checklist. . . . .	146
Data Archive Architecture Recommendations. . . . .	146
Component Diagram for Data Vault. . . . .	147
ILM Engine and Informatica Data Vault. . . . .	147
Data Vault Architecture with Data Validation Option. . . . .	148
Data Vault Architecture with the Federation and Visualization Option. . . . .	148
Data Vault Architecture for Scaling Agents on Multiple Nodes. . . . .	149
Data Vault Configuration for High Availability. . . . .	149
Active-Passive Data Vault Server with Active-Active Data Vault Query. . . . .	150
Data Archive Repositories. . . . .	151
<b>Index. . . . .</b>	<b>152</b>

# Preface

Follow the instructions in the *Data Archive Installation and Upgrade Guide* to install or upgrade Data Archive and Data Vault. The guide includes information on minimum requirements, prerequisite tasks, and post installation tasks. The guide also includes information about installing application accelerators and upgrading application history data.

## Informatica Resources

Informatica provides you with a range of product resources through the Informatica Network and other online portals. Use the resources to get the most from your Informatica products and solutions and to learn from other Informatica users and subject matter experts.

### Informatica Network

The Informatica Network is the gateway to many resources, including the Informatica Knowledge Base and Informatica Global Customer Support. To enter the Informatica Network, visit <https://network.informatica.com>.

As an Informatica Network member, you have the following options:

- Search the Knowledge Base for product resources.
- View product availability information.
- Create and review your support cases.
- Find your local Informatica User Group Network and collaborate with your peers.

### Informatica Knowledge Base

Use the Informatica Knowledge Base to find product resources such as how-to articles, best practices, video tutorials, and answers to frequently asked questions.

To search the Knowledge Base, visit <https://search.informatica.com>. If you have questions, comments, or ideas about the Knowledge Base, contact the Informatica Knowledge Base team at [KB\\_Feedback@informatica.com](mailto:KB_Feedback@informatica.com).

### Informatica Documentation

Use the Informatica Documentation Portal to explore an extensive library of documentation for current and recent product releases. To explore the Documentation Portal, visit <https://docs.informatica.com>.

If you have questions, comments, or ideas about the product documentation, contact the Informatica Documentation team at [infa\\_documentation@informatica.com](mailto:infa_documentation@informatica.com).

## Informatica Product Availability Matrices

Product Availability Matrices (PAMs) indicate the versions of the operating systems, databases, and types of data sources and targets that a product release supports. You can browse the Informatica PAMs at <https://network.informatica.com/community/informatica-network/product-availability-matrices>.

## Informatica Velocity

Informatica Velocity is a collection of tips and best practices developed by Informatica Professional Services and based on real-world experiences from hundreds of data management projects. Informatica Velocity represents the collective knowledge of Informatica consultants who work with organizations around the world to plan, develop, deploy, and maintain successful data management solutions.

You can find Informatica Velocity resources at <http://velocity.informatica.com>. If you have questions, comments, or ideas about Informatica Velocity, contact Informatica Professional Services at [ips@informatica.com](mailto:ips@informatica.com).

## Informatica Marketplace

The Informatica Marketplace is a forum where you can find solutions that extend and enhance your Informatica implementations. Leverage any of the hundreds of solutions from Informatica developers and partners on the Marketplace to improve your productivity and speed up time to implementation on your projects. You can find the Informatica Marketplace at <https://marketplace.informatica.com>.

## Informatica Global Customer Support

You can contact a Global Support Center by telephone or through the Informatica Network.

To find your local Informatica Global Customer Support telephone number, visit the Informatica website at the following link:

<https://www.informatica.com/services-and-training/customer-success-services/contact-us.html>.

To find online support resources on the Informatica Network, visit <https://network.informatica.com> and select the eSupport option.

# CHAPTER 1

## Installation Overview

This chapter includes the following topics:

- [Introduction, 12](#)
- [Data Archive Installation, 13](#)
- [Data Vault Installation, 13](#)
- [Component Selection, 14](#)
- [Application Accelerator Installation, 15](#)
- [Dynamic Data Masking Installation, 15](#)

## Introduction

Data Archive helps you manage the data growth in production applications and data retirement in legacy and redundant applications.

When you use Data Archive to archive inactive or infrequently accessed data out of the production database, you can improve application response time and still comply with data retention policies. You can move data to a separate partition within the same database or to another database instance and keep data online for user access. You can also archive inactive data to a highly-compressed Data Vault that makes data available for search, query, and reporting.

The Data Archive installation involves the following installers:

### **Data Archive Installer**

Use the Data Archive installer to install the components that extract and archive data from sources. The Data Archive components include a metadata repository and the Data Archive user interface. You can also use the Data Archive installer to install the Data Visualization option.

### **Data Vault Installer**

To archive inactive data to the Data Vault, use the Data Vault installer to install the Data Vault components. The components include a Data Vault plug-in that adds Data Vault functionality to Data Archive. The plug-in enables Data Archive to load data into the Data Vault.

### **Application Accelerator Installer**

Use the application accelerator installer to install pre-packaged metadata for business applications. Each application has a separate installer.

On Windows, you can run the installers in graphical or silent mode. On UNIX, you can run the installers in graphical, console, or silent mode. The silent mode installation uses a properties file to determine how to configure the installation options.

# Data Archive Installation

You can install the Data Archive components on separate machines. Run the installer for each component that you want install.

Use the Data Archive installer to install the following components:

## Data Archive

When you install Data Archive, you can install the following components separately:

- ILM Engine and Repository. The ILM Engine is the main component of the Data Archive product that performs the data archive processes. It uses the ILM repository to store metadata for Data Archive objects such as user accounts and roles, job definitions, and job schedules. During installation, provide the database connection information so that the installer can create the repository.
- Data Vault Loader and Data Discovery. The Data Vault Loader communicates with the Data Vault Service to load data to the Data Vault. You can use the Data Discovery portal to search and view data in the Data Vault.
- Data Vault Service for External Attachments. This web application manages external attachments for data in the Data Vault.

## Data Visualization

You can use Data Visualization to create reports based on archive data in the Data Vault. You must install Data Visualization in the Data Archive directory.

# Data Vault Installation

You can install the Data Vault components on separate machines. You must run the installer for each component that you want install.

Use the Data Vault installer to install the following components:

## Data Vault Service

The Data Vault Service includes all components required to store data to and retrieve data from the Data Vault. The Data Vault Service installation includes a load balancer and the Data Vault Agent and Data Vault ODBC driver.

## Data Vault Agent

The Data Vault Agent handles query requests to the Data Vault. You can install multiple Data Vault Agents on multiple machines.

## Data Vault ODBC driver

The Data Vault ODBC driver is designed to work with the Data Vault. Install the Data Vault ODBC driver on any machine that contains an ODBC application that you want to use to connect to the Data Vault.

## Data Vault Data Archive plug-in

The Data Vault plug-in enables Data Archive to load data to the Data Vault. Install the plug-in on the machine that hosts Data Archive. Data Archive must be running when you install the Data Vault plug-in.

## Data Vault Administration Tool and SQL Tool

The Data Vault Administration Tool provides a graphical user interface to configure and manage the Data Vault and its components. Install the Administrator Tool on the machine where you want to manage

the Data Vault Service. You can use the SQL tool installed with the Administrator Tool to query data in the Data Vault.

## Component Selection

You install different components based on the type of archive and the tasks that you want to perform.

You can use Data Archive to archive data to a database or to a Data Vault. To archive data to a database only, you need to run only the Data Archive installer. To archive data to a database or to a Data Vault, you must run the Data Archive installer and the Data Vault installer.

### Archive to Database

You can archive data to a separate partition within the same database or to another database instance.

To archive data to a separate partition within the same database or to another database instance, install the following Data Archive components:

- ILM Engine and Repository

You can install the ILM Engine and ILM Repository on one machine or on multiple machines. You do not need to install Data Vault Service components.

### Archive to Database or Data Vault

You can archive data to a database or to a Data Vault.

To archive data to a database or to a Data Vault, install the following Data Archive components:

- ILM Engine and Repository

Then, install the following Data Vault Service components:

- Data Vault Service
- Data Vault Service Data Archive Plug-in
- Data Vault Service Administrator Console and Query Tool. Optional. The Data Vault Service component includes an administration command line program to manage the Data Vault Service and its components. To use a graphical tool to manage the Data Vault Service, install the Data Vault Service Administrator Console and Query Tool.
- Data Vault Agent. Optional. The Data Vault Service component includes the Data Vault Agent component to handle client requests. To increase the number of agents to handle client requests, you can additionally install the Data Vault Agent component on another machine. You can install the Data Vault Agent on multiple machines.

### Queries and Reports on Archived Data

To run queries and reports on archived data, install the following Data Archive component:

- Data Visualization. Use Data Visualization to create reports based on data archived in the Data Vault.

You can also install the following Data Vault Service components to query data in the Data Vault:

- Data Vault Service ODBC Driver. Use this ODBC driver with a query or reporting tool to access data in the Data Vault.

- Data Vault Service Administrator Console and Query Tool. This component Includes the SQL Worksheet that you could use to run queries on data in the Data Vault.

## Application Accelerator Installation

After you install Data Archive, install the accelerator for the ERP application from which you want to archive data. Each ERP application has a corresponding application accelerator installer. For example, if you want to archive data from SAP Application Retirement, use the SAP Application Retirement Accelerator installer. You install the accelerators in the root installation of the Data Archive installation.

An application accelerator contains a set of business rules that enable Data Archive to manage transaction tables used by a specific enterprise resource planning (ERP) application. The accelerators include entities and related metadata. An entity is a predefined logical grouping of related tables that correspond to a business object. An entity contains all tables that collectively consist of the business object transactions, such as the master data, transactional data, and application data.

You can install application accelerators for the following ERP systems:

- SAP Application Retirement Accelerator

When you install the application accelerator, the installer adds the entities and all related metadata to the ILM repository. You can view the entities and related metadata in the Enterprise Data Manager. For SAP application retirement, the installer also publishes pre-packaged reports to the data visualization server.

## Dynamic Data Masking Installation

Dynamic Data Masking is a data security product that operates between an application and a database to prevent unauthorized access to sensitive information. Dynamic Data Masking intercepts requests sent to the database and applies data masking rules to the request to mask the data before it is sent back to the application.

You can use Dynamic Data Masking to mask or prevent access to sensitive data stored in Data Vault. To install Dynamic Data Masking, see the *Informatica Dynamic Data Masking Installation and Upgrade Guide*.

### Enabling Dynamic Data Masking

To implement Dynamic Data Masking for Data Vault, perform the following tasks:

1. Before you configure Dynamic Data Masking, create the Data Vault archive folder in the Data Archive target connection.
2. Install the Dynamic Data Masking Server and Management Console.  
For more information, see the *Informatica Dynamic Data Masking Installation and Upgrade Guide*.
3. In the Dynamic Data Masking Management Console, configure Dynamic Data Masking for the Data Vault.
  - a. Add the Data Vault service in the Management Console.
  - b. Define the listener port for the Data Vault service.
  - c. Define the Data Vault connection in the Management Console.

- d. Create a security rule set and define security rules.
- e. Create connection rules.

For more information about Dynamic Data Masking services and connection management, see the *Informatica Dynamic Data Masking Administrator Guide*. For more information about Dynamic Data Masking connection rules and security rule sets, see the *Informatica Dynamic Data Masking User Guide*.

- 4. Enable Dynamic Data Masking in Data Archive.
- 5. Define the Data Vault host and port parameters in Data Archive.
- 6. Create Data Archive access roles.
- 7. Assign access roles to users.
- 8. Update the target connection with the Dynamic Data Masking host name and port.

For more information about how to set up and use the Dynamic Data Masking Accelerator for Data Archive, see the *Informatica Dynamic Data Masking Data Archive Accelerator Guide*.



## CHAPTER 2

# Before You Install

This chapter includes the following topics:

- [License Key, 17](#)
- [X Window Server, 17](#)
- [Data Archive Requirements for the ILM Repository, 17](#)
- [Data Archive Requirements for the ILM Engine, 20](#)
- [Data Vault Requirements, 21](#)

## License Key

Before you install, verify that you have the license key available. You can get the license key when you download the installation files from the Informatica FTP site. The license key is included in an email message from Informatica. Copy the license key file to a directory accessible to the user account installing Data Archive.

Contact Informatica Global Customer Support if you do not have a license key.

## X Window Server

If you choose to install Data Archive in graphical mode, your system requires a graphics display server.

On UNIX, the graphics display server is usually an X Window server. Before you begin the installation, install and configure an X Window server on the machine where you plan to install Data Archive.

## Data Archive Requirements for the ILM Repository

The ILM repository is a collection of database objects stored in a single database user or schema, usually called AMHOME. The objects are stored in the data tablespace and index tablespace.

You can create the ILM repository on Oracle, Microsoft SQL Server, or IBM DB2.

You can create the ILM repository database user and tablespaces before you install or you can let the installer create them. You must use the same method to create them. For example, if you create the ILM repository database user before you install, you must also create the tablespaces before you install.

During the installation, you specify the data connection information to create or access the ILM repository. Use the admin user or any other database user that has the required privileges.

The following table describes the ILM repository tablespace requirements:

Tablespace	Tablespace Size
Data Default is AM_DATA.	3 GB
Index Default is AM_INDEX.	3 GB
Rollback	1 GB
Temporary	2 GB

## IBM DB2 Requirements

You can create tablespaces for the ILM repository before the installation. If you do not create the tablespaces manually before the installation, the installer creates them when it creates the ILM repository. Use the following guidelines when you set up the ILM repository on IBM DB2:

- Create the ILM repository schema, and grant authorization to a user.

For example, use the following syntax to create the ILM repository schema:

```
CREATE SCHEMA <schema> AUTHORIZATION <user>
```

To create the AMHOME schema and grant authorization to the ILMUSER user, use the following sample syntax:

```
CREATE SCHEMA AMHOME AUTHORIZATION ILMUSER
```

- Create the tablespaces.

Set the tablespace page sizes and the buffer pool page sizes to at least 32 KB. Set the page sizes to the same value. The tablespaces must not be partitioned.

For example, use the following syntax to create a tablespace:

```
CREATE REGULAR TABLESPACE <tablespace name>
PAGE SIZE 32K
MANAGED BY DATABASE
USING ( FILE '/db2fs/db2inst1/NODE0000/DB2/T0000000/<tablespace name>' 3145728K )
BUFFERPOOL AM32KBFPL
```

To create the ILMTS tablespace, use the following sample syntax:

```
CREATE REGULAR TABLESPACE ILMTS
PAGE SIZE 32K
MANAGED BY DATABASE
USING ( FILE '/db2fs/db2inst1/NODE0000/DB2/T0000000/ILMTS' 3145728K )
BUFFERPOOL AM32KBFPL
```

- Grant the user access to the tablespaces.

For example, use the following syntax to grant the user access to a tablespace:

```
GRANT USE OF TABLESPACE <tablespace name> to <user>
```

To grant the ILMUSER to the ILMTS tablespace, use the following sample syntax:

```
GRANT USE OF TABLESPACE ILMTS to ILMUSER
```

## Microsoft SQL Server Requirements

If you create the ILM repository on Microsoft SQL Server, the Admin user must have the SYSADMIN role.

If you create the Data Archive server repository on a Microsoft SQL Server, set the Database Collation property value to CASE INSENSITIVE.

## ILM Repository User

The ILM repository user creates and owns the database objects in the ILM repository schema. The database objects contain repository data such as application metadata, users, jobs, and workbench definitions. The ILM repository user is also called the AMHOME user.

Data Archive requires the ILM repository user. You can create the user before the installation, or the installation can create the user and grant the required privileges.

For example, you can run the following script to create the ILM repository user:

```
create user username identified by username default tablespace tablespace_name temporary
tablespace TEMP;
```

The following table lists the privileges required for the ILM repository:

Oracle Privileges	Microsoft SQL Server Privileges	IBM DB2 Privileges
ALTER SESSION	ALTER EVENT SESSION	ALTER SESSION
CONNECT	For information about creating connections to the SQL Server database, see <a href="http://msdn.microsoft.com/en-us/library/s4yys16a(v=vs.90).aspx">http://msdn.microsoft.com/en-us/library/s4yys16a(v=vs.90).aspx</a>	CONNECT
CREATE DATABASE LINK	Not applicable	Not applicable
CREATE PROCEDURE	CREATE PROCEDURE	CREATE PROCEDURE
CREATE SEQUENCE	CREATE SEQUENCE	CREATE SEQUENCE
CREATE SESSION	CREATE EVENT SESSION	CREATE EVENT SESSION
CREATE SYNONYM	CREATE SYNONYM	CREATE SYNONYM
CREATE TABLE	CREATE TABLE	CREATE TABLE
CREATE TYPE	CREATE TYPE	CREATE TYPE
CREATE VIEW	CREATE VIEW	CREATE VIEW
DEFAULT ROLE ALL	Default roles enabled when user logs in.	Not applicable

## IBM DB2 Privileges

You must create the database schema for the ILM repository before the installation. The user that has authorization to the ILM repository schema must have access to the catalog tables.

## Installation on SSL Enabled Databases

If you are using an SSL enabled database to install the ILM repository, you must import the SSL certificates from the database server into the Java truststore on the ILM installation host machine.

You must import SSL certificates to the Azul Java truststore available in the following path:

```
<DA Installer build>/DA/<windows/linux java>
```

## Data Archive Requirements for the ILM Engine

The machine on which you install the ILM Engine must meet certain requirements.

### System User Account

The user account that runs the Data Archive installer must have read and write privileges on the installation directory.

### System Requirements

The following table describes the system requirements for the ILM Engine and Data Archive installer:

Component	System Requirements
ILM Engine	<ul style="list-style-type: none"><li>- 2 GB heap space memory</li><li>- Dual-core processor</li><li>- Arial Unicode MS (ARIALUNI.TTF) font must be installed in the following directory: &lt;ILM Products Installation Directory&gt;\webapp\WEB-INF\classes The font is used to generate reports and support non-Roman alphabets. <b>Note:</b> Restart the ILM application server after installing the ARIALUNI.TTF file.</li><li>- The Linux or Windows user that starts the ILM application server must have read and write access to a directory with space for 50% of the data to be archived in a single job.</li></ul>
Data Archive Installer	<ul style="list-style-type: none"><li>- Available disk space for temporary files: 1 GB for Data Archive, 2 GB for each accelerator</li></ul>

### Port Availability

The ILM application server must run on a unique port.

Use a port number higher than 1024 so that you do not have to log in as the root user to start the service.

### Java Requirements

The ILM Engine requires the Java Development Kit (JDK).

The Data Archive installer comes bundled with Azul OpenJDK. You do not need to configure the JAVA\_HOME variable.

**Note:** Data Archive works with the Java version that ships with the installer. Do not use other downloaded JDKs.

If JAVA\_HOME is already configured and added to PATH, then the installer uses this variable.

## Database Client

Data Archive can use native utilities for data movement on IBM DB2 and Teradata databases.

### IBM DB2 Requirements

You can configure Data Archive to use IBM DB2 native utilities for data movement. To use IBM DB2 native utilities to export and import data, you must install the ILM Engine on the machine that hosts IBM DB2 Connect. If you use the IBM DB2 HPU for data export, you must install the IBM DB2 HPU utility on the machine that hosts the ILM Engine.

### Teradata Requirements

By default, archive, retirement, and restore jobs use Teradata JDBC FastExport to export data from Teradata. You can configure Data Archive to use Teradata Parallel Transporter to export data from Teradata to the Data Vault. To use Teradata Parallel Transporter to export data, you must install the Teradata Parallel Transporter client on the machine that hosts the ILM Engine.

## Data Vault Requirements

Verify the installation requirements for the Data Vault.

You install the Data Vault separately from Data Archive. The Data Vault components have a separate set of installation requirements.

## System User Account

On UNIX, create a system account specifically to install and run the Data Vault Service.

The user account that installs the Data Vault Service must have read and write permission on the installation directory.

The user account that runs the Data Vault Service must the following minimum resource allocation:

- 4 GB RAM
- Unlimited virtual memory
- 32 MB stack size
- 1024 open files

## System Requirements

You can install the Data Vault components on separate machines. You must install the Data Vault Data Archive plug-in on the machine that hosts the Data Archive ILM Engine.

Verify the system requirements before you install the Data Vault components. When you install a Data Vault component, verify that the machine has enough disk space for the component and the installer.

The following table describes the minimum system requirements for the Data Vault components and the Data Vault installer:

Component	System Requirements
All components	<ul style="list-style-type: none"> <li>- Windows: 64-bit processor</li> <li>- UNIX: 64-bit processor</li> </ul>
Data Vault Service	<ul style="list-style-type: none"> <li>- Processor: 4 CPU</li> <li>- RAM: 8 GB</li> <li>- Disk space for component files: 100 MB</li> <li>- Disk space for log files: 2 GB</li> </ul>
Data Vault Agent	<ul style="list-style-type: none"> <li>- Processor: 2 CPU</li> <li>- RAM: 4 GB</li> <li>- Disk space for component files: 10 MB</li> <li>- Disk space for log files: 2 GB</li> </ul>
Data Vault Data Archive plug-in	The plug-in must be installed on a machine that hosts the ILM Engine. The system requirements are the same as the ILM Engine. The plug-in files require 10 MB disk space.
Data Vault Service Administration Tool and SQL Tool	<ul style="list-style-type: none"> <li>- Processor: 2 CPU</li> <li>- RAM: 1 GB</li> <li>- Disk space: 10 MB</li> </ul>
Data Vault ODBC driver	The ODBC driver must be installed on the machine that hosts the ODBC client application. The ODBC driver requires 10 MB disk space.
glibc-locale-base-32bit	Required on Linux and SUSE Linux Enterprise servers to allow 32-bit components of Data Vault to work.
libncurses.so5 and libnsl.so.1	Required on Linux and SUSE Linux Enterprise servers. Installation fails if you install Data Vault on a machine without the dependent library files.
Data Vault installer	In addition to the disk space requirements for each component, the Data Vault installer requires 75 MB of disk space.

## Java Requirements

The Data Vault installation requires the Java Development Kit (JDK).

The Data Archive installer comes bundled with Azul OpenJDK. You do not need to set the JAVA\_HOME environment variable. If you want to use another JDK, you must set JAVA\_HOME to that JDK.

On all operating systems, if you set the JAVA\_HOME environment variable, begin the path with `JAVA_HOME/bin`.

If JAVA\_HOME is already set and added to PATH, then this JAVA\_HOME setting will be used for the installation.

## Curl Requirements

The Data Vault installation requires Curl libraries and the path variable to be set to the required libraries.

If the version of RHEL 8 server libraries is incompatible with the OpenSSL version that Data Vault uses, you might encounter a symbol lookup error.

On RHEL 8 machines, build Curl 1.1.1k libraries and export the path to the LD\_LIBRARY\_PATH environment variable. Restart the Data Archive and Data Vault servers to update the change.

## Visual C++

On Windows, the Data Vault components require Visual C++.

Install the following Visual C++ package according to your Windows installation:

### 64-bit

On 64-bit Microsoft Windows installations, install the following Microsoft Visual C++ Redistributable Packages for Visual Studio 2019:

- Microsoft Visual C++ Redistributable Package for Visual Studio 2019 (64-bit).
- Microsoft Visual C++ Redistributable Package for Visual Studio 2019(32-bit).

### 32-bit

On 32-bit Microsoft Windows installations, install Microsoft Visual C++ Redistributable Package for Visual Studio 2019 (32-bit).

Verify that you have the correct package and service pack. Data Vault does not work with other versions of Visual C++.

## Port Number Requirements

The installer configures ports for the Data Vault Service. You can specify the port numbers to use or you can use the default port numbers provided by the installer.

Verify that the port numbers are available on the machine where you install the Data Vault Service. If the port numbers are not available, the Data Vault Service installation fails.

When you install the Data Vault Agent, you need to indicate the port number used by the Data Vault Service.

The following table describes the ports used by the Data Vault Service:

Port Type	Description
Server port	Port number used by the Data Vault Administration Tool and command line program to connect to the Data Vault Service. Default is 8500.
Server Execution Port	Port number used by the Data Vault Agent to connect to the Data Vault Service. Default is 8600. This port number is required when you install the Data Vault Service and Data Vault Agent components.
Metadata Port	Port number that the Data Vault Service uses to connect to the Data Vault repository. Default is 50501.

## Data Vault Space Requirements

The Data Vault Service requires space for data in the Data Vault.

The Data Vault Service stores compressed data in the Data Vault. Typically, the Data Vault requires 10 to 15 percent of the space required for the source data to be archived. The space for the Data Vault can be local to the Data Vault Service or on a shared Network File System (NFS) directory.

# CHAPTER 3

## Data Archive Installation

This chapter includes the following topics:

- [Data Archive Installation Overview, 24](#)
- [Installing Data Archive Components, 25](#)
- [Graphical Mode Installation, 25](#)
- [Console Mode Installation, 33](#)
- [Silent Mode Installation, 38](#)

### Data Archive Installation Overview

The Data Archive installer is included in the installation zip files. Use the installer for the following actions:

- Install Data Archive components. Use the Data Archive installer to install Data Archive components, including the ILM Engine and repository, the Data Vault Loader and Data Discovery, the Data Vault Service for External Attachments, and Data Visualization. The installation configures metadata and imports it into the ILM repository the first time you install Data Archive.

**Note:** Ensure that installation and accelerator patches are installed in different directories. This will prevent errors if the `installer.properties` file is not deleted during installation.

The installer can create the ILM repository database user and tablespaces if you did not create them prior to the installation.

- Install hotfixes. Use the Data Archive installer to install hotfixes. When you install Data Archive, Data Archive is packaged with the current hotfix level. First install the base installation version, then install hotfixes that are released subsequent to the installation version. Because hotfixes are cumulative, you only need to apply the latest one.

The following table describes possible installation scenarios:

Scenario	Action
You want to install Data Archive and you do not have any other Informatica ILM products.	Install Data Archive and the accelerators. Except for Data Visualization, each Data Archive component will require you to run the installer again.
You want to install Data Archive and you have an existing Informatica ILM product. For example, you are installing Data Archive 6.2. You have Data Subset for 5.3.3.	Install Data Archive and the accelerators. You must install Data Archive with a separate repository than the existing product.



## Installation Package

Use installation zip files to install or upgrade Data Archive and the accelerators or to install hotfixes. Get the zip files from the Download Manager or from a DVD. Follow the installation instructions on where to extract the files to.

# Installing Data Archive Components

You can install Data Archive in graphical, console, or silent mode. Installing in graphical mode on UNIX requires a graphical display server, typically an X Window server.

You can install the following components:

### **ILM Engine and Repository**

Installs Data Archive and configures the repository database. You must install this component before you install either the Data Vault Service for External Attachments or the Data Vault Loader and Data Discovery components. This component is also required to install the Data Visualization component. You can install the Data Visualization component after you install the ILM Engine and repository, or you can install the components simultaneously.

### **Data Vault Loader and Data Discovery**

Installs the Data Vault Loader and Data Discovery components and configures the web application. Choose this option if you want to archive using the Data Vault Service. You must install the ILM Engine and repository before you install the Data Vault Loader and Data Discovery. You cannot install the component with any other Data Archive component.

### **Data Vault Service for External Attachments**

Installs the web application for archiving to the Data Vault. You must install the ILM Engine and repository before you install the Data Vault Service for External Attachments. You cannot install the component with any other Data Archive component.

### **Data Visualization**

Installs the Data Visualization component so that you can create reports on data in the Data Vault. The ILM Engine and repository component is required to install Data Visualization. You can install the Data Visualization component after you install the ILM Engine and repository, or you can install the components simultaneously. UNIX installations must have a minimum of 300 MB of space available in the \tmp folder. You must also have a license that allows you to install the Data Visualization component.

Run the installer again to install additional components.

## Graphical Mode Installation

You can install in graphical mode on Linux, UNIX, or Windows.

When you run the Data Archive installer in graphical mode, you must use a graphics display server. On UNIX, the graphics display server is typically an X Window server.

During the installation process, you will be asked to either create a repository or provide details to an existing repository.

## Installing the ILM Engine and Repository

1. Go to the directory where you extracted the files from Informatica\_ILM\_<release>.zip, for example, Informatica\_ILM\_61.zip.

**Note:** The name of this directory and the full path to the directory can contain only the following characters: English letters (A-Z and a-z), numbers (0-9), hyphens(-), underscores(\_), and periods(.). Verify that only these characters appear in the directory path before you proceed with the installation.

2. With administrator privileges, run one of the following commands:

- On Windows operating systems, run `install.cmd`.
- On UNIX based operating systems, run `install.sh`.

The **Welcome** page of the ILM installer appears.

3. Click **Next**.

The **Installation Mode** page appears.

4. Select **Install Data Archive** and click **Next**.

The **License Agreement** page appears. Accept the terms of the license agreement, and click **Next**.

The **License Key** page appears.

5. Enter the path and file name of the license key file, and click **Next**.

The **Installation Folder** page appears.

6. Click **Choose** and browse to the installation directory.

The directory names in the path cannot contain spaces or any of the following special characters:

```
@ | * $ # ! % ( ) { } [ ] , ; ' "
```

7. Click **Next**.

The **Components to Install** page appears.

8. Select the checkbox next to **Data Archive** and the radio button next to **ILM Engine and Repository**.

9. Click **Next**.

The **New or Existing Repository** page appears.

10. Choose whether to use an existing repository or create a new one during the installation.

- Select **Repository Already Exists** to reuse an existing repository or if you created the schema, tablespaces, and filegroups before the installation.  
For installation on IBM DB2, you must select this option. You must create the ILM repository schema and tablespaces before you install.

Click **Next** and enter the database connection details listed in the following table.

Field	Description
Database Type	Database for the ILM repository, usually called AMHOME. You can install the ILM repository on Oracle, Microsoft SQL Server, or IBM DB2.
Database URL	Host name and port number for the database instance or Microsoft SQL Server instance. Enter in the following format: <code>&lt;host name&gt;:&lt;port number&gt;</code>  For a Microsoft SQL Server with SSL enabled, enter in the following format: <code>&lt;host name&gt;:&lt;port number&gt;;ValidateServerCertificate=&lt;false/true&gt;;CryptoProtocolVersion=&lt;TLS version. Example: TLSv1.2&gt;</code>  If the same machine hosts both the ILM repository and Data Archive web server, the database URL must not be a loopback URL, for example 127.0.0.1 or localhost. If the database URL is a loopback, the Enterprise Data Manager will fail to connect to the ILM repository database. Use a host name or IP number that is compatible with all potential clients. For example, remote employees in your organization may only be able to connect to the database with a full domain name. If the ILM repository is located in an Oracle Real Application cluster, enter the RAC SCAN host name and verify that the cluster has more than one node. If the cluster has one node, the ILM application server might not start if the node is unavailable.
Repository Schema Name	A unique placeholder for tables. This placeholder is different from the default placeholder. On an Oracle database, the repository schema name must be the same as the repository login name.
Repository Login Name	Login name for a user who has full access to the repository schema. On an Oracle database, the repository login name must be the same as the repository schema name. If you install Data Visualization, the repository login name cannot contain the following special characters: @ :
Repository Password	Password for the ILM repository database user or login. If you install Data Visualization, the repository password cannot contain the following special characters: @ :
Database Service Name	ILM repository database service name or database name. <b>Note:</b> JDBC connections use the Oracle service name to connect to the database. The Oracle service name may not be the same as the Oracle SID. Use the following SQL statement to determine the database service name: <pre>select name, value from v\$parameter where name = 'service_names';</pre>
Data Tablespace Name	Tablespace or data filegroup name, such as AM_DATA. Not required for Data Vault Loader and Data Discovery installation.

Field	Description
Index Tablespace Name	Index tablespace or filegroup name, such as AM_INDEX. Not required for Data Vault Loader and Data Discovery installation.
SSL Enabled	Check box to confirm the AMHOME database is SSL enabled. <b>Note:</b> This property is supported for Oracle 11g and later.

- Clear **Repository Already Exists** to create the ILM repository. You must create the ILM repository if you are installing Data Archive for the first time and you did not create the schema prior to the installation. Or, clear this option if you created the schema but did not create tablespaces and filegroups prior to the installation.

Click **Next** and enter the database connection details listed in the following table.

Field	Description
Database Type	Database for the ILM repository, usually called AMHOME. If you install Data Archive only, you can install the ILM repository on Oracle or Microsoft SQL Server. For IBM DB2, you must select the previous option, "Repository Already Exists."
Database URL	Host name and port number for the database instance or Microsoft SQL Server instance. Enter in the following format: <code>&lt;host name&gt;:&lt;port number&gt;</code>  For a Microsoft SQL Server with SSL enabled, enter in the following format: <code>&lt;host name&gt;:&lt;port number&gt;;ValidateServerCertificate=&lt;false/true&gt;;CryptoProtocolVersion=&lt;TLS version. Example: TLSv1.2&gt;</code>  If you want to locate the ILM repository in an Oracle Real Application cluster, enter the RAC SCAN host name and verify that the cluster has more than one node. If the cluster has one node, the ILM application server might not start if the node is unavailable.
Database User ID	Admin database user that has required privileges to create or access the ILM repository user/schema. This can be the system or any other admin user. If you install Data Visualization, the database user ID cannot contain the following special characters: @ :
Password	Password for the ILM repository database user or login. If you install Data Visualization, the database user password cannot contain the following special characters: @ :

Field	Description
Database Service Name	<p>ILM repository database service name or database name.</p> <p><b>Note:</b> JDBC connections use the Oracle service name to connect to the database. The Oracle service name may not be the same as the Oracle SID. Use the following SQL statement to determine the database service name:</p> <pre>select name, value from v\$parameter where name = 'service_names';</pre>
SSL Enabled	<p>Check box to confirm the AMHOME database is SSL enabled.</p> <p><b>Note:</b> This property is supported for Oracle 11g and later.</p>

11. Optionally, click **Test Connection** to test the connection details.
12. Click **Next**.  
The **Configure ILM Repository** page appears.
13. Optionally, select **Create Tablespaces** to create tablespaces or filegroups for the ILM repository. If you created the tablespaces or filegroups before the installation, do not select this option.
14. Enter the following information to create the ILM repository. The fields appear based on whether you choose to create the tablespaces. The installation uses the following information to create the user, tablespaces or filegroups, and data files:

Tablespace Status	Field	Description
New Tablespaces Existing Tablespaces	User Name	ILM repository user account.
New Tablespaces Existing Tablespaces	Password	Password for the ILM repository user account.
New Tablespaces Existing Tablespaces	Data Tablespace Name	Name of the tablespace or filegroup in which to create the ILM repository tables, such as AM_DATA. If blank, the installation creates the repository tables in the default tablespace or filegroup.
New Tablespaces Existing Tablespaces	Index Tablespace Name	Name of the index tablespace or filegroup, such as AM_INDEX.
New Tablespaces	Data Tablespace Size (MB)	Size of the tablespace or filegroup. Minimum recommended size is 3000 MB.
New Tablespaces	Data File Name and Location	File name and path for the tablespace or filegroup data file. For example: C:\oracle\oradata\orc111\AM_DATA

Tablespace Status	Field	Description
New Tablespaces	Index Tablespace Size (MB)	Size of the index tablespace or filegroup. Minimum recommended size is 3000 MB.
New Tablespaces	Index File Name and Location	File name and path for the tablespace .dbf file. For example: C:\oracle\oradata\orc111\AM_INDEX

- Click **Next**.

The **Pre-installation Summary** page displays the installation directory and the products that you selected to install.

- Click **Install**.

The installer creates the ILM repository if the repository does not exist. The installer adds the database objects and Data Archive metadata to the ILM repository. It also creates a web interface directory on the server.

- Click **Done** to complete the installation.

The installer produces a log file about the installation tasks and errors that occurred during installation. You can find the installation log file, `ILMInstaller.log`, in the installation directory.

## Installing Data Visualization

If you have a license for the Data Visualization component, you must install it after installing the ILM Engine and repository or simultaneously with the ILM Engine and repository.

The steps to install Data Visualization are identical to ILM Engine and repository installation, but you must select the checkbox next to **Data Visualization** along with the radio button next to **ILM Engine and Repository**.

If you have installed the ILM Engine and repository, run the installer again and select only the checkbox next to **Data Visualization**. You will not need to enter the connection details for the ILM Engine and repository.

## Installing Data Vault Loader and Data Discovery

Before you install the Data Vault Loader, you must install Data Archive with the ILM Engine and Repository component.

- Go to the directory where you extracted the files from `Informatica_ILM_<release>.zip`, for example, `Informatica_ILM_61.zip`.
- With administrator privileges, run one of the following commands:
  - On Windows operating systems, run `install.cmd`.
  - On UNIX based operating systems, run `install.sh`.

The **Welcome** page of the ILM installer appears.

- Click **Next**.

The **Installation Mode** page appears.

- Select **Install Data Archive** and click **Next**.

If you purchased ILM products from Symantec, the **License Agreement** page appears. Accept the terms of the license agreement, and click **Next**.

The **License Key** page appears.

5. Enter the path and file name of the license key file, and click **Next**.  
The **Installation Folder** page appears.
6. Enter the absolute path of the directory that you used to install the ILM Engine and repository.  
The directory names in the path cannot contain spaces or any of the following special characters:  
@ | \* \$ # ! % ( ) { } [ ] , ; '
  7. Click **Next**.  
The **Components to Install** page appears.
  8. Select the checkbox next to **Data Archive** and the radio button next to **Data Vault Loader and Data Discovery**, then click **Next**.  
The **Configure ILM Repository** page appears.
  9. Enter the connection details for the database where you created the ILM repository.  
The following table describes the database credentials:

Field	Description
Database Type	Database for the ILM repository, usually called AMHOME. You can install the ILM repository on Oracle, Microsoft SQL Server, or IBM DB2.
Database URL	Host name and port number for the database instance or Microsoft SQL Server instance. Enter in the following format: <host name>:<port number>
Repository Schema Name	A unique placeholder for tables. This placeholder is different from the default placeholder.
Repository Login Name	Login name for a user who has full access to the repository schema. If you install Data Visualization, the repository login name cannot contain the following special characters: @ :
Repository Password	Password for the ILM repository database user or login. If you install Data Visualization, the repository password cannot contain the following special characters: @ :
Database Service Name	ILM repository database service name or database name. <b>Note:</b> JDBC connections use the Oracle service name to connect to the database. The Oracle service name may not be the same as the Oracle SID. Use the following SQL statement to determine the database service name: <pre>select name, value from v\$parameter where name = 'service_names';</pre>
Data Tablespace Name	Tablespace or data filegroup name, such as AM_DATA. Not required for Data Vault Loader and Data Discovery installation.

Field	Description
Index Tablespace Name	Index tablespace or filegroup name, such as AM_INDEX. Not required for Data Vault Loader and Data Discovery installation.
SSL Enabled	Check box to confirm the AMHOME database is SSL enabled. <b>Note:</b> SSL Enabled is only available when the ILM repository is on Oracle 11g or Oracle 12c.

10. Click **Install**.  
The **Pre-installation Summary** page displays the installation directory and the component you selected to install.
11. Review the installation details and click **Install**.
12. The **Install Complete** page indicates whether the installation completed successfully.
13. Click **Done** to complete the installation.

## Installing Data Vault Service for External Attachments

Before you install Data Vault Service for External Attachments, you must install Data Archive with the ILM Engine and Repository component.

1. Go to the directory where you extracted the files from Informatica\_ILM\_<release>.zip, for example, Informatica\_ILM\_61.zip.
2. With administrator privileges, run one of the following commands:
  - On Windows operating systems, run `install.cmd`.
  - On UNIX based operating systems, run `install.sh`.

The **Welcome** page of the ILM installer appears.
3. Click **Next**.  
The **Installation Mode** page appears.
4. Select **Install Data Archive** and click **Next**.  
If you purchased ILM products from Symantec, the **License Agreement** page appears. Accept the terms of the license agreement, and click **Next**.  
The **License Key** page appears.
5. Enter the path and file name of the license key file, and click **Next**.  
The **Installation Folder** page appears.
6. Enter the absolute path of the installation directory. Specify a different directory than the directory that you used to install the ILM Engine and repository. The directory must be empty.  
The directory names in the path cannot contain spaces or any of the following special characters:  

```
@ | * $ # ! % ( ) { } [ ] , ; ' "
```
7. Click **Next**.  
The **Components to Install** page appears.
8. Select **Data Vault Service for External Attachments**, and click **Next**.  
The **Pre-installation Summary** page appears.
9. Review the installation details, and click **Install**.



The **Installation Complete** page indicates whether the installation completed successfully.

10. Click **Done** to complete the installation.

## Applying a HotFix

1. Go to the directory where you extracted the files from Informatica\_ILM\_<release>\_<hotfix>.zip. For example, Informatica\_ILM\_65.zip.
2. With administrator privileges, run one of the following commands:
  - On Windows operating systems, run `install.cmd`.
  - On UNIX based operating systems, run `install.sh`.

The **Welcome** page of the ILM installer appears.

3. Click **Next**.
4. Select **Upgrade from previous version of Data Archive** and click **Next**.
5. Provide the absolute path of the ILM installation directory and click **Next**.

The **Pre-installation Summary** page displays the installation directory details and the products that you selected to upgrade.

6. Click **Install**.

The **Installation Complete** page indicates whether the upgrade completed successfully.

7. Click **Done** to exit the installer.

## Console Mode Installation

You can install Data Archive in console mode on UNIX or Linux.

1. On a shell command line, navigate to the installation directory where you extracted the files from Informatica\_ILM\_<release>\_<hotfix>.zip.

**Note:** The name of this directory and the full path to the directory can contain only the following characters: English letters (A-Z and a-z), numbers (0-9), hyphens(-), underscores(\_), and periods(.). Verify that only these characters appear in the directory path before you proceed with the installation.

2. Run `install.sh`.

The Welcome text appears.

3. Press Enter.
4. Choose to install the product or a hotfix:
  - To install the product, type 1, and then press Enter.
  - To install a hotfix, type 2, and then press Enter. Go to step [7](#).
5. The license agreement appears. To accept the terms of the license agreement, type Y, and then press Enter.
6. Enter the path and file name of the license key file, then press Enter.
7. Enter the absolute path for the installation directory.
  - To accept the default installation location, press Enter.

- For Data Vault Loader and Data Discovery installation, choose the Data Archive installation directory that contains the ILM Engine and repository.
  - For Data Vault Service for External Applications installation, choose a different installation directory from the Data Archive installation. The directory must be empty.
8. To confirm the installation location, type Y.  
For hotfixes, go to step [15](#).
  9. Enter 1 to install Data Archive.
  10. You can install the following Data Archive components:

Data Archive Components	Description
ILM Engine and Repository	Installs the base Data Archive product and configures the repository database. You must install this component before you install Data Vault Loader and Data Discovery and the Data Vault Service for External Attachments. This component is required to install the Data Visualization.
Data Vault Loader and Data Discovery	Installs the Data Vault Loader and Data Discovery components and configures the web application. Choose this option if you want to archive to file. You must install the ILM Engine and repository before installing this component. You cannot install this component with any other Data Archive component.
Data Vault Service for External Attachments	Installs the web application for archiving external attachments to the file-based archive. You must install the ILM Engine and repository before installing this component. You cannot install this component with any other Data Archive component.
Data Visualization	Installs the Data Visualization component so that you can create reports. To install this component, you must also select the ILM Engine and Repository component.

11. Select to create or reuse an ILM repository.  
To create the ILM repository, type N. You must create the ILM repository if this is the first time that you are installing Data Archive and you did not create the schema before installation. Or, select this option if you created the schema but did not create tablespaces and filegroups before installation.  
For installation on IBM DB2, you must create the ILM repository schema and tablespaces before you install.  
Press Enter.

Enter the database connection details to create the ILM repository. For Data Vault Loader and Data Discovery installation, enter the database connection details for the ILM repository. The following table describes the database credentials:

Field	Description
Database Type	Database for the ILM repository, such as AMHOME. You can install the ILM repository on Oracle, Microsoft SQL Server, or IBM DB2.
Database URL	Host name and port number for the database instance or SQL server instance. Enter in the following format: <host name>:<port number>
Repository Schema Name	A unique placeholder for tables. This placeholder is different from the default placeholder. If you have already created the repository, the repository schema name must be the same as the repository login name on Oracle databases.
Repository Login Name	Login name for a user who has full access to the repository schema. If you have already created the repository, the repository login name must be the same as the repository schema name on Oracle databases. If you install Data Visualization, the repository login name cannot contain the following special characters: @ :
Repository Password	Password for the ILM repository database user or login. If you install Data Visualization, the repository password cannot contain the following special characters: @ :
Database Service Name/ Database Name	ILM repository database service name or database name. <b>Note:</b> JDBC connections use the Oracle service name to connect to the database. The Oracle service name may not be the same as the Oracle SID. Use the following SQL statement to determine the database service name:  <pre>select name, value from v\$parameter where name = 'service_names';</pre>
SSL Enabled	Check box to confirm the AMHOME database is SSL enabled. <b>Note:</b> SSL Enabled is only available when the ILM repository is on Oracle 11g or Oracle 12c.

-or-

To use an existing ILM repository, type Y. Select this option to use an existing ILM repository, or if you created the schema, tablespaces, and filegroups before installation.  
Press Enter.

Enter the database connection details to access the ILM repository. For Data Vault Loader and Data Discovery installation, enter the database connection details for the ILM repository. The following table describes the database credentials:

Field	Description
Database Type	Database for the ILM repository, such as AMHOME. You can install the ILM repository on Oracle, Microsoft SQL Server, or IBM DB2.
Database URL	Host name and port number for the database instance or SQL server instance. Enter in the following format: <host name>:<port number>
Repository Schema Name	A unique database placeholder for tables. This placeholder is different from the default placeholder.
Repository Login Name	Login name for a user who has full access to the repository schema. If you install Data Visualization, the repository login name cannot contain the following special characters: @ :
Repository Password	Password for the ILM repository database user or login. If you install Data Visualization, the repository password cannot contain the following special characters: @ :
Database Service Name/ Database Name	ILM repository database service name or database name. <b>Note:</b> JDBC connections use the Oracle service name to connect to the database. The Oracle service name may not be the same as the Oracle SID. Use the following SQL statement to determine the database service name:  <pre>select name, value from v\$parameter where name = 'service_names';</pre>
Data Tablespace/ Filegroup Name	Tablespace or data filegroup name, such as AM_DATA. Not required for Data Vault Loader and Data Discovery installation.
Index Tablespace/ Filegroup Name	Index tablespace or filegroup name, such as AM_INDEX. Not required for Data Vault Loader and Data Discovery installation.
SSL Enabled	Check box to confirm the AMHOME database is SSL enabled. <b>Note:</b> SSL Enabled is only available when the ILM repository is on Oracle 11g or Oracle 12c.

- For Data Vault Loader and Data Discovery installation, go to step [15](#).

13. Enter the following information to create the ILM repository. The fields shown depend on if you select the option to create the tablespaces. The installation uses the following information to create the user, the tablespaces or filegroups, and the data files:

Tablespace Status	Field	Description
New Tablespaces Existing Tablespaces	User Name	ILM repository user account.
New Tablespaces Existing Tablespaces	Database Name (SQL)	Database for ILM repository, such as AMHOME.
New Tablespaces Existing Tablespaces	Password	Password for the ILM repository user account.
New Tablespaces Existing Tablespaces	Create Tablespaces?	Enter Y to create tablespaces or filegroups for the ILM repository. Enter N if you created the tablespaces or filegroups before installation. For installation on IBM DB2, enter N. You must create the ILM repository schema and tablespaces before you install.
New Tablespaces Existing Tablespaces	Data Tablespace Name	Name of the tablespace or filegroup in which to create the ILM repository tables, such as AM_DATA. If blank, the installation creates the repository tables in the default tablespace or filegroup.
New Tablespaces Existing Tablespaces	Index Tablespace Name	Name of the index tablespace or filegroup, such as AM_INDEX.
New Tablespaces	Data Tablespace Size (MB)	Size of the tablespace or filegroup. Minimum recommended size is 3000 MB.
New Tablespaces	Data File Name & Location	File name and path for the tablespace or filegroup data file. For example: C:\oracle\oradata\orc111\AM_DATA
New Tablespaces	Index Tablespace Size (MB)	Size of the index tablespace or filegroup. Minimum recommended size is 3000 MB.
New Tablespaces	Index File Name and Location	File name and path for the tablespace .dbf file. For example: C:\oracle\oradata\orc111\AM_INDEX

14. Press Enter.

The Pre-Installation Summary displays the installation directory and the products that you selected to install.

15. Press Enter to start the installation.

The installer creates the ILM repository if the repository does not exist. The installer adds the database objects and the product metadata to the ILM repository. It also creates a web interface directory on the server.

16. The Post-Installation Summary indicates whether the installation completed successfully.

The installer produces a log file about the installation tasks and errors that occurred during installation. You can find the installation log file, `ILMInstaller.log`, in the installation directory.

## Silent Mode Installation

To install or upgrade Data Archive without user interaction, install in silent mode. You can use silent installation to install Data Archive, upgrade Data Archive, or install the Data Vault Service for External Attachments component.

To specify the installation options, use the `SilentInstall.properties` file inside the `DA` folder in the installer. The installer reads information in the properties file to determine the installation options. You can use silent mode installation to install Data Archive on multiple machines on the network or to standardize the installation across machines.

To specify the options for your installation, customize the sample properties file. Make a backup copy of the properties file before you customize it.

Installing Data Archive in silent mode takes a few minutes. On UNIX, the installer displays a message to alert you that the installation completed. On Windows, check the installation log file to verify that the installation completed successfully.

## Silent Mode Installation Properties

The `SilentInstall.properties` file contains parameters for silent mode installation. Update the properties to specify the options for your installation or upgrade.

### New Installation Properties

If you upgrade Data Archive, the installation program ignores the new installation properties.

The following properties apply to new installations:

#### **INSTALLATION\_TYPE**

Installation type, either `PRODUCT`, `PATCH`, or `ACCELERATORS`. For normal installations, set `INSTALLATION_TYPE=PRODUCT`.

#### **NEW\_INSTALL, UPGRADE**

Installation mode. You can install or upgrade Data Archive.

To install Data Archive, set `NEW_INSTALL=1` and `UPGRADE=0`. To upgrade Data Archive, set `NEW_INSTALL=0` and `UPGRADE=1`.

#### **PA\_LICENSE\_FILE**

License key file and location. Enter the path and the file name of the license key file.

For Data Vault Service for External Applications installation, specify an empty directory that is different from the Data Archive installation directory.

## DATA\_VISUALIZATION

Data visualization properties.

Select one of the following options:

- To skip installation of the Data Visualization component, set `DATA_VISUALIZATION=0` and `DATA_VISUALIZATION_UPGRADE=0`.
- To install the Data Visualization component, set `DATA_VISUALIZATION=1` and `DATA_VISUALIZATION_UPGRADE=0`.

## INSTALL\_ARCHIVE

To install Data Archive, set `INSTALL_ARCHIVE=true`. If you set this property to false, the installation program does not install any ILM product.

## ILM\_PRODUCT\_SELECTED, FASA

Controls whether to install the ILM Engine and repository or the Data Vault Service for External Attachments.

To install the ILM Engine and repository, set `ILM_PRODUCT_SELECTED=1` and comment the FASA property. To install the Data Vault Service for External Attachments (FASA), set `FASA=1` and comment the `ILM_PRODUCT_SELECTED` property.

## USER\_INSTALL\_DIR

Installation directory. Enter the absolute path for the installation directory.

## SCHEMA\_ALREADY\_EXISTS

Controls whether to create or reuse an ILM repository.

If this is the first time that you are installing an ILM product for the release, and you did not create the schema before installation, set `SCHEMA_ALREADY_EXISTS=0`. If you created the schema but did not create tablespaces and filegroups before installation, set `SCHEMA_ALREADY_EXISTS=1`.

For installation on IBM DB2, you must create the ILM repository schema and tablespaces before you install.

## DB\_VERSION, PC\_REPO\_DBTYPE

Database version and type for the database where you want to create or access the ILM repository. You can create the repository in specific versions of IBM DB2, Microsoft SQL Server, or Oracle.

Set these properties as follows:

Database	DB_VERSION Value	PC_REPO_DBTYPE Value
IBM DB2	<code>DB_VERSION=UDB</code>	<code>PC_REPO_DBTYPE=DB2_Adapter</code>
Microsoft SQL Server 2000	<code>DB_VERSION=2000</code>	<code>PC_REPO_DBTYPE=SqlServer</code>
Microsoft SQL Server 2005	<code>DB_VERSION=2005</code>	<code>PC_REPO_DBTYPE=SqlServer</code>
Microsoft SQL Server 2008	<code>DB_VERSION=2008</code>	<code>PC_REPO_DBTYPE=SqlServer</code>
Microsoft SQL Server 2012	<code>DB_VERSION=2012</code>	<code>PC_REPO_DBTYPE=SqlServer</code>
Oracle 8i	<code>DB_VERSION=8i</code>	<code>PC_REPO_DBTYPE=ORACLE</code>

Database	DB_VERSION Value	PC_REPO_DBTYPE Value
Oracle 9i	DB_VERSION=9i	PC_REPO_DBTYPE=ORACLE
Oracle 10g	DB_VERSION=10g	PC_REPO_DBTYPE=ORACLE
Oracle 11g	DB_VERSION=11g	PC_REPO_DBTYPE=ORACLE
Oracle 12c	DB_VERSION=12c	PC_REPO_DBTYPE=ORACLE

#### ADMIN\_UID, ADMIN\_PWD

User name and password for the database user that has privileges to create and access the ILM repository users and the schema. The database user can be the system or any other user with administrator privileges.

If this is a new installation and the repository does not exist in the database, enter the database user name and the password. Otherwise, comment these properties.

#### AM\_HOST, AM\_PORT

Host name and port number of the machine that hosts the ILM repository database.

#### AM\_SID

Database service name of the database that hosts the ILM repository.

**Note:** JDBC connections use the Oracle service name to connect to the database. The Oracle service name might not be the same as the Oracle SID.

Use the following SQL statement to determine the database service name:

```
select name, value from v$parameter where name = 'service_names';
```

#### AM\_UID, AM\_PWD

ILM repository user name and password.

If you install Data Visualization, the ILM repository user name and password cannot contain the following special characters: @ :

#### SSL\_ENABLED

Confirms whether the AMHOME database is SSL enabled. To confirm whether AMHOME is SSL enabled, enter SSL\_ENABLED=true or SSL\_ENABLED=false, respectively.

#### CREATE\_TABLESPACES

Controls whether to create tablespaces or filegroups for the ILM repository.

If the repository exists in the database, set CREATE\_TABLESPACES=0 or comment this property. To use existing tablespaces, set CREATE\_TABLESPACES=0 or comment this property. If the repository does not exist, set CREATE\_TABLESPACES=1 to create tablespace in the database.

For installation on IBM DB2, set CREATE\_TABLESPACES=0. You must create the ILM repository schema and tablespaces before you install.

#### AM\_D\_TSPACE

Name of the tablespace or filegroup in which to create the ILM repository tables, for example, AM\_DATA.



If the repository exists in the database, enter the existing tablespace name. If the repository does not exist and you do not create tablespaces, enter the existing tablespace name. If the repository does not exist and you create tablespaces, verify that the tablespace name does not exist in the database.

If you do not specify a value for this property, the installation program creates the repository tables in the default tablespace or filegroup.

#### **AM\_I\_TSPACE**

Name of the index tablespace or filegroup, for example, AM\_INDEX.

If the repository exists in the database, enter the existing tablespace name. If the repository does not exist and you do not create tablespaces, enter the existing tablespace name. If the repository does not exist and you create tablespaces, verify that the tablespace name does not exist in the database.

#### **AM\_DATA\_FILE\_LOC**

File name and path for the tablespace or filegroup data file. For example, C:\oracle\oradata\orcl11\AM\_DATA.

If the repository does not exist in the database and you create tablespaces, enter a value for this property. Otherwise, comment this property.

#### **AM\_DATA\_FILE\_SIZE**

Size of the data tablespace or filegroup. Minimum recommended size is 3000 MB.

If the repository does not exist in the database and you create tablespaces, enter a value for this property. Otherwise, comment this property.

#### **AM\_IDX\_FILE\_SIZE**

Size of the index tablespace or filegroup. Minimum recommended size is 3000 MB.

If the repository does not exist in the database and you create tablespaces, enter a value for this property. Otherwise, comment this property.

#### **AM\_IDX\_FILE\_LOC**

File name and path for the tablespace .dbf file. For example, C:\oracle\oradata\orcl11\AM\_INDEX.

If the repository does not exist in the database and you create tablespaces, enter a value for this property. Otherwise, comment this property.

### **Upgrade Properties**

The following properties apply to Data Archive upgrades:

#### **INSTALLATION\_TYPE**

Installation type, either PRODUCT, PATCH, or ACCELERATORS. For normal installations, set `INSTALLATION_TYPE=PRODUCT`.

#### **NEW\_INSTALL, UPGRADE**

Installation mode. You can install or upgrade Data Archive.

To install Data Archive, set `NEW_INSTALL=1` and `UPGRADE=0`. To upgrade Data Archive, set `NEW_INSTALL=0` and `UPGRADE=1`.

#### **PA\_LICENSE\_FILE**

License key file and location. Enter the path and the file name of the license key file.

For Data Vault Service for External Applications installation, specify an empty directory that is different from the Data Archive installation directory.

## USER\_INSTALL\_DIR

Installation directory. Enter the absolute path for the installation directory. For new installations, comment this property.

## Installing in Silent Mode

To install in silent mode, update the sample properties file, and then run the installation program with the properties file.

1. Copy the installation files to the hard disk on the machine where you plan to install Data Archive.  
If you install on a remote machine, verify that you can access and create files on the remote machine.
2. Find the `SilentInstall.properties` file and create a backup copy of the file.
3. Use a text editor to open the file and change the values of the installation parameters.
4. Run the installer with the installation properties file.

Use the following syntax:

- Windows: `install.cmd -i silent -f SilentInstall.properties`
- UNIX: `sh install.sh -i silent -f SilentInstall.properties`

If the silent installer properties file is in another directory, specify the full file path to the properties file.  
For example:

```
sh install.sh -i silent -f C:\ILM536Installer\Properties\SilentInstall.properties
```

## CHAPTER 4

# Data Vault Installation

This chapter includes the following topics:

- [Data Vault Installation Overview, 43](#)
- [Graphical Mode Installation, 43](#)
- [Console Mode Installation, 51](#)
- [Silent Mode Installation, 57](#)

## Data Vault Installation Overview

To archive inactive data to the Data Vault, you must install the Data Vault components. The Data Vault components include the Data Archive plug-in that adds Data Vault functionality to Data Archive.

Copy the Data Vault installer files to the machine where you plan to install the Data Vault component. Before you run the Data Vault installer, verify that your environment meets the minimum system requirements, and complete the pre-installation tasks. Run the installer for each component that you install.

On Windows, you can run the Data Vault installer in graphical or silent mode. On UNIX, you can run the installer on graphical, console, or silent mode. The silent mode installation uses a properties file to determine how to configure the installation options.

## Graphical Mode Installation

You can install the Data Vault components in graphical mode on Windows and UNIX.

On UNIX, the Data Vault installer requires an X Window server.

### Installing the Data Vault Service in Graphical Mode

The Data Vault Service installation includes a Data Vault Agent.

1. Log in to the machine with a system user account.
2. Close all other applications.
3. Begin the installation.
  - On Windows, run `install.cmd` from the root directory.

**Note:** On Windows 2012, right-click the command prompt icon and open the command prompt window using "Run As Administrator." Navigate to the installer location and run install.cmd from this command prompt window.

- On UNIX, use a shell command line to run install.sh from the root directory.  
If you do not have an X Window server, the installer runs in console mode.
4. On the **Introduction** page, read the instructions and click **Next**.
  5. On the **Installation Type** page, select **Install a Data Vault component** and click **Next**.
  6. On the **License File** page, enter the path and file name of the Informatica license key or click **Choose** to select a license key file.
  7. Click **Next**.
  8. On the **Component Selection** page, select **Data Vault** and click **Next**.
  9. On the **Installation Directory** page, enter the absolute path for the directory in which to install the Data Vault or click **Choose** to select or create a directory.  
The path must conform to the length and character restrictions of the operating system.
  10. Click **Next**.
  11. On the **Data Vault Configuration** page, set the properties for the Data Vault.  
The following table describes the properties that you set for the Data Vault:

Section	Property	Description
Service Configuration	Port	Port number used by the ssasql command line program and other clients such as the Data Vault SQL Tool and ODBC applications to connect to the Data Vault. Default is 8500.
Service Configuration	Execution port	Port number used by the Data Vault Agent and the Data Vault Administration Tool to connect to the Data Vault. Default is 8600.
Service Configuration	Temporary directory	Directory where the Data Vault Service stores temporary result set files. Default is <DataVaultDirectory>/temp.
Query Configuration	Query threads	Number of threads used by the Data Vault Agent to process client requests to the Data Vault. Default is 2.
Query Configuration	Memory	Maximum amount of memory in megabytes to use for processing client requests to the Data Vault. The Data Vault Service allocates memory dynamically up to the maximum specified in this property. Default is 2048 MB.
Query Configuration	Temporary directory	Directory where the Data Vault Service stores temporary files. Default is <DataVaultDirectory>/temp.
Query Configuration	Share directory	Directory where the Data Vault Service stores temporary files for GROUP BY and ORDER BY queries. This directory must be accessible to the Data Vault Agent. If you install multiple agents, this directory must be accessible to all agents. Default is <DataVaultDirectory>/share.

Section	Property	Description
Query Configuration	Index directory	Directory where the Data Vault Service stores index files when you create indexes for archived tables. Default is <DataVaultDirectory>/index.
Metadata Repository Configuration	Port	Port number that the Data Vault Service uses to connect to the Data Vault repository. Default is 50501.
Metadata Repository Configuration	Cache size (in MB)	Maximum amount of memory that the Data Vault Service uses for caching during database operations. The cache can have a minimum of 64 megabytes and a maximum of 1024 megabytes of memory. Default is 1024 MB. If this property is set to a value that is not within the allowed range, the Data Vault Service uses the default.
Log File Configuration	Server log directory	Directory where the Data Vault Service stores server logs. Default is <DataVaultDirectory>/fas_logs.
Log File Configuration	Agent log directory	Directory where the Data Vault Service stores logs generated by the Data Vault Agents. Default is <DataVaultDirectory>/fas_agent_logs.
Log File Configuration	Starter log directory	Directory where the Data Vault Service stores logs generated during initialization. Default is <DataVaultDirectory>/fas_logs.
Log File Configuration	Service log directory	Directory where the Data Vault Service stores service logs. Default is <DataVaultDirectory>/fas_logs.

12. Click **Next**.
13. On the **Data Vault Administrator** page, set the properties for the Data Vault administrator user account. The following table describes the properties that you set for the Data Vault administrator user account:

Property	Description
User name	Name of the default administrator user account. The Data Vault Administration Tool, command line program, and other client applications use this user account to connect to the Data Vault. The installer sets the name of the user account to <i>dba</i> . You cannot change the user name during installation.
Password	Password for the default administrator user account.
Confirm password	Verification of the password for the default administrator user account.

14. Click **Next**.
15. On the **Connection Configuration** page, enter the names for the Data Vault connections.

The following table describes the connections the installer creates for the Data Vault:

Connection	Description
Data Vault repository connection name	Name of the connection to the Data Vault repository that the installer creates. The Data Vault Service uses this connection to connect to the Data Vault repository. Default name is <i>meta</i> .
Data Vault connection name	Name of the connection to the Data Vault Service that the installer creates. Client applications can use this connection to connect to the Data Vault Service for query requests. Default name is <i>fas</i> .

Use different names for each connection.

- Click **Next**.

On Windows, you can install the Data Vault Service as a Windows service. You can configure the service for automatic startup. You can also specify the user account to run the service. By default, the service runs under the LocalSystem account. You can run the Windows service under a different user account.

- Select **Install as a Windows service** to install the Data Vault Service as a Windows service.

The following table describes the properties that you can set for the Windows service:

Property	Description
Install as a Windows service	Indicates whether to install the Data Vault Service as a Windows service. Default is False.
Number of agents to start	Number of instances of the Data Vault Agent to start immediately after the Data Vault Service starts. Default is 2.
Start Windows service automatically	Indicates whether to start the Windows service immediately after the machine starts. Default is False.
Use local system account to start the Windows service	Indicates whether to run the Windows service under the LocalSystem account. Default is True.
Use another account to start the Windows service	Indicates whether to run the Windows service under another user account that you specify. If you do not set this option, the service runs under the LocalSystem account. Default is False.
User name	User account with which to run the Windows service. Use the following format: <code>DomainName\UserAccount</code> This user account must have the Act as operating system permission. Required if you select the option to use another account to start the Windows service.
Password	Password for the user account that runs the Windows service.
Confirm password	Verification of the password for the user account that runs the Windows service.

- Click **Next**.

- On the **Pre-installation Summary** page, review the installation information, and click **Install** to continue.

The installer copies the Data Vault Service files to the installation directory. After the installation process completes, the **Installation Complete** page indicates whether the installation completed successfully.

20. Click **Done**.

The installer creates a log file named *FAS-installer.log* in the root of the directory that contains the installer files. You can view the installer log file to get more information about the tasks that are performed by the installer and to view configuration properties for the installed component.

## Installing the Data Vault Agent in Graphical Mode

You can install the Data Vault Agent on multiple machines.

1. Log in to the machine with a system user account.
2. Close all other applications.
3. Begin the installation.
  - On Windows, run `install.cmd` from the root directory.

**Note:** On Windows 2012, right-click the command prompt icon and open the command prompt window using "Run As Administrator." Navigate to the installer location and run `install.cmd` from this command prompt window.
  - On UNIX, use a shell command line to run `install.sh` from the root directory.

If you do not have an X Window server, the installer runs in console mode.
4. On the **Introduction** page, read the instructions and click **Next**.
5. On the **Installation Type** page, select **Install a Data Vault component** and click **Next**.
6. On the **License File** page, enter the path and file name of the Data Vault license key or click **Choose** to select a license key file.
7. On the **Components Selection** page, select **Data Vault Agent** and click **Next**.
8. On the **Installation Directory** page, enter the absolute path for the directory in which to install the Data Vault Agent or click **Choose** to select or create a directory.

The path must conform to the length and character restrictions of the operating system.
9. Click **Next**.
10. On the **Data Vault Agent Configuration** page, set the properties for the Data Vault Agent.

The following table describes the properties that you set for the Data Vault Agent:

Section	Property	Description
Server Configuration	Host name	Host name or IP address of the machine that hosts the Data Vault Service.
Server Configuration	Execution port	Port number used by the Data Vault Agent and the Data Vault Administration Tool to connect to the Data Vault. Default is 8600.
Agent Configuration	Temporary directory	Directory where the Data Vault Service stores temporary result set files. Default is <code>&lt;DataVaultAgentDirectory&gt;/temp</code> .
Agent Configuration	Log directory	Directory where the Data Vault Service stores logs generated by the Data Vault Agents. Default is <code>&lt;DataVaultAgentDirectory&gt;/fas_agent_logs</code> .

Section	Property	Description
Agent Configuration	Share directory	Directory where the Data Vault Service stores temporary files for GROUP BY and ORDER BY queries. This directory must be accessible to the Data Vault Agent. If you install multiple agents, this directory must be accessible to all agents. Default is <DataVaultAgentDirectory>/share.
Agent Configuration	Index directory	Directory where the Data Vault Service stores index files when you create indexes for archived tables. Default is <DataVaultAgentDirectory>/index.
Query Configuration	Threads	Number of threads used by the Data Vault Agent to process client requests to the Data Vault. Default is 2.
Query Configuration	Memory	Maximum amount of memory in megabytes to use for processing client requests to the Data Vault. The Data Vault Service allocates memory dynamically up to the maximum specified in this property. Default is 2048 MB.

- Click **Next**.

On Windows, you can install the Data Vault Agent as a Windows service. You can configure the service for automatic startup. You can also specify the user account to run the service. By default, the service runs under the LocalSystem account. You can run the Windows service under a different user account.

- Select **Install as a Windows service** to install the Data Vault Agent as a Windows service.

The following table describes the properties that you can set for the Windows service:

Property	Description
Install as a Windows service	Indicates whether to install the Data Vault Service as a Windows service. Default is False.
Number of agents to start	Number of instances of the Data Vault Agent to start immediately after the Data Vault Service starts. Default is 2.
Start Windows service automatically	Indicates whether to start the Windows service immediately after the machine starts. Default is False.
Use local system account to start the Windows service	Indicates whether to run the Windows service under the LocalSystem account. Default is True.
Use another account to start the Windows service	Indicates whether to run the Windows service under another user account that you specify. If you do not set this option, the service runs under the LocalSystem account. Default is False.
User name	User account with which to run the Windows service. Use the following format: DomainName\UserAccount Required if you select the option to use another account to start the Windows service.



Property	Description
Password	Password for the user account that runs the Windows service. Required if you select the option to run the Windows service under another user account.
Confirm Password	Verification of the password for the user account that runs the Windows service.

13. Click **Next**.
14. On the **Pre-installation Summary** page, review the installation information, and click **Install** to continue.  
The installer copies the Data Vault Agent files to the installation directory. After the installation process completes, the **Installation Complete** page indicates whether the installation completed successfully.
15. Click **Done**.  
The installer creates a log file named *FAS-installer.log* in the root of the directory that contains the installer files. You can view the installer log file to get more information about the tasks that are performed by the installer and to view configuration properties for the installed component.

## Installing the Data Vault ODBC Driver in Graphical Mode

You can install the Data Vault ODBC driver in graphical mode on Windows and UNIX. Install the ODBC driver on the machine that hosts the application you plan to use to access the Data Vault.

1. Log in to the machine with a system user account.
2. Close all other applications.
3. Begin the installation.
  - On Windows, run `install.cmd` from the root directory.  
**Note:** On Windows 2012, right-click the command prompt icon and open the command prompt window using "Run As Administrator." Navigate to the installer location and run `install.cmd` from this command prompt window.
  - On UNIX, use a shell command line to run `install.sh` from the root directory.  
If you do not have an X Window server, the installer runs in console mode.
4. On the **Introduction** page, read the instructions and click **Next**.
5. On the **Installation Type** page, select **Install a Data Vault component** and click **Next**.
6. On the **License File** page, enter the path and file name of the Data Vault license key or click **Choose** to select a license key file.
7. On the **Components to Install** page, select **Data Vault ODBC Driver** and click **Next**.
8. On the **Installation Directory** page, enter the absolute path for the directory in which to install the Data Vault ODBC driver or click **Choose** to select or create a directory.  
The path must conform to the length and character restrictions of the operating system.
9. Click **Next**.
10. On the **Pre-installation Summary** page, review the installation information, and click **Install** to continue.  
The installer copies the Data Vault ODBC driver files to the installation directory. After the installation process completes, the **Installation Complete** page indicates whether the installation completed successfully.
11. Click **Done**.

The installer creates a log file named *FAS-installer.log* in the root of the directory that contains the installer files. You can view the installer log file to get more information about the tasks that are performed by the installer and to view configuration properties for the installed component.

## Installing the Data Vault Data Archive Plug-in in Graphical Mode

You must install the Data Vault Data Archive plug-in on a machine that hosts Data Archive. Verify that Data Archive is running when you install the Data Archive plug-in.

1. Log in to the machine with a system user account.
2. Close all other applications.
3. Begin the installation.
  - On Windows, run `install.cmd` from the root directory.

**Note:** On Windows 2012, right-click the command prompt icon and open the command prompt window using "Run As Administrator." Navigate to the installer location and run `install.cmd` from this command prompt window.
  - On UNIX, use a shell command line to run `install.sh` from the root directory.

If you do not have an X Window server, the installer runs in console mode.
4. On the **Introduction** page, read the instructions and click **Next**.
5. On the **Installation Type** page, select **Install a Data Vault component** and click **Next**.
6. On the **License File** page, enter the path and file name of the Data Vault license key or click **Choose** to select a license key file.
7. On the **Components to Install** page, select **Data Vault Data Archive Plug-in** and click **Next**.
8. On the **Installation Directory** page, enter the absolute path for the installation directory or click **Choose** to select or create a directory.

The installation directory for the Data Archive plug-in must be the root directory of an instance of Data Archive.
9. Click **Next**.
10. On the **Pre-installation Summary** page, review the installation information, and click **Install** to continue.

The installer copies the Data Archive plug-in files to the installation directory. After the installation process completes, the **Installation Complete** page indicates whether the installation completed successfully.
11. Click **Done**.

The installer creates a log file named *FAS-installer.log* in the root of the directory that contains the installer files. You can view the installer log file to get more information about the tasks that are performed by the installer and to view configuration properties for the installed component.

## Installing the Data Vault Administration Tool and SQL Tool in Graphical Mode

You can install the Data Vault Administration Tool and SQL Tool on Windows. The Data Vault query tool is called SQL Worksheet. The SQL Worksheet installation includes the Data Vault ODBC driver.

1. Log in to the machine with a system user account.
2. Close all other applications.
3. Begin the installation.

- On Windows, run `install.cmd` from the root directory.  
**Note:** On Windows 2012, right-click the command prompt icon and open the command prompt window using "Run As Administrator." Navigate to the installer location and run `install.cmd` from this command prompt window.
  - On UNIX, use a shell command line to run `install.sh` from the root directory.  
 If you do not have an X Window server, the installer runs in console mode.
4. On the **Introduction** page, read the instructions and click **Next**.
  5. On the **Installation Type** page, select **Install a Data Vault component** and click **Next**.
  6. On the **License File** page, enter the path and file name of the Data Vault license key or click **Choose** to select a license key file.
  7. On the **Components to Install** page, select **Data Vault Administration Tool and SQL Tool** and click **Next**.
  8. On the **Installation Directory** page, enter the absolute path for the directory in which to install the Administration Tool and the SQL Tool or click **Choose** to select or create a directory.  
 Choose an empty directory. The installer will quit if the directory contains files. The path must conform to the length and character restrictions of the operating system.
  9. Click **Next**.
  10. On the **Pre-installation Summary** page, review the installation information, and click **Install** to continue.  
 The installer copies the Administration Tool and SQL Tool files to the installation directory. After the installation process completes, the **Installation Complete** page indicates whether the installation completed successfully.
  11. Click **Done**.  
 The installer creates a log file named *FAS-installer.log* in the root of the directory that contains the installer files. You can view the installer log file to get more information about the tasks that are performed by the installer and to view configuration properties for the installed component.

## Console Mode Installation

You can install all Data Vault components in console mode on UNIX except the Data Vault Administration Tool and SQL Tool. The Data Vault Administration Tool and SQL Tool are available only on Windows.

### Installing the Data Vault Service in Console Mode

The Data Vault Service installation includes a Data Vault Agent.

1. Log in to the machine with a system user account.
2. Close all other applications.
3. On a shell command line, run the `install.sh` file from the root of the directory where the installation files are located.  
 The **Introduction** section appears.
4. Press ENTER to continue.  
 The **Installation Type** section appears.
5. Press 1 to install a Data Vault component and press ENTER.

The **License File** section appears.

6. Type the full path and file name of the Data Vault license key and press ENTER.

The **Select a Component to Install** section appears.

7. Press 1 to install the Data Vault Service and press ENTER.

The **Specify the Installation Directory** section appears.

8. Type the path for the directory in which to install the Data Vault Service or press ENTER to use the default directory.
9. Verify that the installation directory is correct and press Y to continue.
10. In the **Data Vault Configuration** section, set the properties for the Data Vault Service.

The following table describes the properties that you set for the Data Vault Service:

Section	Property	Description
Service Configuration	Port	Port number used by the ssasql command line program and other clients such as the Data Vault SQL Tool and ODBC applications to connect to the Data Vault. Default is 8500.
-	Execution port	Port number used by the Data Vault Agent and the Data Vault Administration Tool to connect to the Data Vault. Default is 8600.
-	Temporary directory	Directory where the Data Vault Service stores temporary result set files. Default is <DataVaultDirectory>/temp.
Query Configuration	Query threads	Number of threads used by the Data Vault Agent to process client requests to the Data Vault. Default is 2.
-	Memory	Maximum amount of memory in megabytes to use for processing client requests to the Data Vault. The Data Vault Service allocates memory dynamically up to the maximum specified in this property. Default is 2048 MB.
-	Temporary directory	Directory where the Data Vault Service stores temporary files. Default is <DataVaultDirectory>/temp.
-	Share directory	Directory where the Data Vault Service stores temporary files for GROUP BY and ORDER BY queries. This directory must be accessible to the Data Vault Agent. If you install multiple agents, this directory must be accessible to all agents. Default is <DataVaultDirectory>/share.
-	Index directory	Directory where the Data Vault Service stores index files when you create indexes for archived tables. Default is <DataVaultDirectory>/index.
Metadata Repository Configuration	Metadata port	Port number that the Data Vault Service uses to connect to the Data Vault repository. Default is 50501.

Section	Property	Description
-	Cache Size (in MB)	Maximum amount of memory that the Data Vault Service uses for caching during database operations. The cache can have a minimum of 64 megabytes and a maximum of 1024 megabytes of memory. Default is 1024 MB. If this property is set to a value that is not within the allowed range, the Data Vault Service uses the default.
Log File Configuration	Server log directory	Directory where the Data Vault Service stores server logs. Default is <DataVaultDirectory>/fas_logs.
-	Agent log directory	Directory where the Data Vault Service stores logs generated by the Data Vault Agents. Default is <DataVaultDirectory>/fas_agent_logs.
-	Starter log directory	Directory where the Data Vault Service stores logs generated during initialization. Default is <DataVaultDirectory>/fas_logs.
-	Service log directory	Directory where the Data Vault Service stores service logs. Default is <DataVaultDirectory>/fas_logs.

- Review the configuration summary and press Y to continue.
- In the **Data Vault Administrator** section, set the properties for the Data Vault administrator user account. The following table describes the properties that you set for the Data Vault administrator user account:

Property	Description
User name	Name of the default administrator user account. The Data Vault Administration Tool, command line program, and other client applications use this user account to connect to the Data Vault. The installer sets the name of the user account to <i>dba</i> . You cannot change the user name during installation.
Password	Password for the default administrator user account.
Confirm password	Verification of the password for the default administrator user account.

- Enter the names for the Data Vault connections. The following table describes the connection the installer creates for the Data Vault Service:

Connection	Description
Data Vault connection name	Name of the connection to the Data Vault Service that the installer creates. Client applications can use this connection to connect to the Data Vault Service for query requests. Default name is <i>fas</i> .

Use different names for the connections.

- Review the connection summary and press Y to continue. The **Pre-Installation Summary** section appears.

15. Review the installation information, and press ENTER to continue.

The installer copies the Data Vault Service files to the installation directory. After the installation process completes, the installer indicates whether the installation completed successfully.

16. Press ENTER to exit the installer.

The installer creates a log file named *FAS-installer.log* in the root of the directory that contains the installer files. You can view the installer log file to get more information about the tasks that are performed by the installer and to view configuration properties for the installed component.

## Installing the Data Vault Agent in Console Mode

You can install the Data Vault Agent on multiple machines.

1. Log in to the machine with a system user account.
2. Close all other applications.
3. On a shell command line, run the *install.sh* file from the root of the directory where the installation files are located.

The **Introduction** section appears.

4. Press ENTER to continue.

The **Installation Type** section appears.

5. Press 1 to install a Data Vault component and press ENTER.

The **License File** section appears.

6. Type the full path and file name of the Data Vault license key and press ENTER.

The **Select a Component to Install** section appears.

7. Press 2 to install the Data Vault Agent and press ENTER.

The **Specify the Installation Directory** section appears.

8. Type the path for the directory in which to install the Data Vault Agent or press ENTER to use the default directory.

9. Verify that the installation directory is correct and press Y to continue.

10. Set the properties for the Data Vault Agent.

The following table describes the properties that you set for the Data Vault Agent:

Section	Property	Description
Service Configuration	Host name	Host name or IP address of the machine that hosts the Data Vault Service.
-	Execution port	Port number used by the Data Vault Agent and the Data Vault Administration Tool to connect to the Data Vault. Default is 8600.
Agent Configuration	Temporary directory	Directory where the Data Vault Service stores temporary result set files. Default is <DataVaultAgentDirectory>/temp.

Section	Property	Description
-	Log directory	Directory where the Data Vault Service stores logs generated by the Data Vault Agents. Default is <DataVaultAgentDirectory>/fas_agent_logs.
-	Share directory	Directory where the Data Vault Service stores temporary files for GROUP BY and ORDER BY queries. This directory must be accessible to the Data Vault Agent. If you install multiple agents, this directory must be accessible to all agents. Default is <DataVaultAgentDirectory>/share.
-	Index directory	Directory where the Data Vault Service stores index files when you create indexes for archived tables. Default is <DataVaultAgentDirectory>/index.
Query Configuration	Threads	Number of threads used by the Data Vault Agent to process client requests to the Data Vault. Default is 2.
-	Memory	Maximum amount of memory in megabytes to use for processing client requests to the Data Vault. The Data Vault Service allocates memory dynamically up to the maximum specified in this property. Default is 2048 MB.

11. Review the configuration summary and press Y to continue.  
The **Pre-Installation Summary** section appears.
12. Review the installation information, and press ENTER to continue.  
The installer copies the Data Vault Agent files to the installation directory. After the installation process completes, the installer indicates whether the installation completed successfully.
13. Press ENTER to exit the installer.  
The installer creates a log file named *FAS-installer.log* in the root of the directory that contains the installer files. You can view the installer log file to get more information about the tasks that are performed by the installer and to view configuration properties for the installed component.

## Installing the Data Vault ODBC Driver in Console Mode

You can install the Data Vault ODBC driver in console mode on UNIX. Install the ODBC driver on the machine that hosts the application you plan to use to access the Data Vault.

**Note:** On zLinux, you can install the Data Vault ODBC driver to query the Data Vault on Linux or Windows.

1. Log in to the machine with a system user account.
2. Close all other applications.
3. On a shell command line, run the `install.sh` file from the root of the directory where the installation files are located.

**Note:** If you are installing the Data Vault ODBC driver on a zLinux environment, you must unzip the installation file (`Informatica_Data_Vault_Native_Install_ODBC_zLinux_x64_6.4.3.zip`) and then navigate to the installer directory (`Informatica_Data_Vault_Native_Install_ODBC_zLinux_x64_6.4.3`). To give the `install.bin` file permission to execute, run the following command: `chmod +x install.bin`

At the prompt, use the following syntax to install: `./install.bin`

- The **Introduction** section appears.
4. Press ENTER to continue.  
The **Installation Type** section appears.
  5. Press 1 to install a Data Vault component and press ENTER.  
The **License File** section appears.
  6. Type the full path and file name of the Data Vault license key and press ENTER.  
The **Select a Component to Install** section appears.
  7. Press 3 to install the Data Vault ODBC driver and press ENTER.  
The **Specify the Installation Directory** section appears.
  8. Type the path for the directory in which to install the Data Vault ODBC driver or press ENTER to use the default directory.
  9. Verify that the installation directory is correct and press Y to continue.  
The **Pre-Installation Summary** section appears.
  10. Review the installation information, and press ENTER to continue.  
The installer copies the files to the installation directory. After the installation process completes, the installer indicates whether the installation completed successfully.
  11. Press ENTER to exit the installer.  
The installer creates a log file named *FAS-installer.log* in the root of the directory that contains the installer files. You can view the installer log file to get more information about the tasks that are performed by the installer and to view configuration properties for the installed component.

## Installing the Data Vault Data Archive Plug-in in Console Mode

You must install the Data Vault Data Archive plug-in on a machine that hosts Data Archive. Verify that Data Archive is running when you install the Data Archive plug-in.

1. Log in to the machine with a system user account.
2. Close all other applications.
3. On a shell command line, run the `install.sh` file from the root of the directory where the installation files are located.  
The **Introduction** section appears.
4. Press ENTER to continue.  
The **Installation Type** section appears.
5. Press 1 to install a Data Vault component and press ENTER.  
The **License File** section appears.
6. Type the full path and file name of the Data Vault license key and press ENTER.  
The **Select a Component to Install** section appears.
7. Press 4 to install the Data Vault Data Archive plug-in and press ENTER.  
The **Specify the Installation Directory** section appears.
8. Type the path for the installation directory or press ENTER to use the default directory.  
The installation directory for the Data Archive plug-in must be the root directory of an instance of Data Archive.
9. Verify that the installation directory is correct and press Y to continue.



The **Pre-Installation Summary** section appears.

10. Review the installation information, and press ENTER to continue.

The installer copies the Data Vault Data Archive plug-in files to the installation directory. After the installation process completes, the installer indicates whether the installation completed successfully.

11. Press ENTER to exit the installer.

The installer creates a log file named *FAS-installer.log* in the root of the directory that contains the installer files. You can view the installer log file to get more information about the tasks that are performed by the installer and to view configuration properties for the installed component.

## Silent Mode Installation

To install the Data Vault components without user interaction, install the Data Vault components in silent mode.

Use a properties file to specify the installation options. The installer reads the file to determine the installation options. You can use silent mode installation to install the Data Vault components on multiple machines on the network or to standardize the installation across machines. Set the values in the properties file and run the silent installer separately for each component that you want to install.

Copy the Data Vault installer files to the machine where you plan to install a Data Vault component.

To install in silent mode, perform the following tasks:

1. Create the installation properties file and specify the installation options.
2. Run the installer with the installation properties file.

### Step 1. Create the Properties File

Informatica provides a sample properties file that includes the parameters that are required by the Data Vault installer. You can customize the sample properties file to specify the options for your installation.

The sample properties file is named *SilentInput.properties* and is located in the root directory of the installation DVD or the installer download location. After you customize the file, save it back to the same file name *SilentInput.properties*.

1. Go to the root of the directory that contains the installer files.
2. Find the file named *SilentInput.properties*.  
Back up the file before you modify it.
3. Use a text editor to open the file and modify the values of the parameters.

The following table describes the installation parameters that you must set:

Property Name	Description
INSTALL_TYPE_NEW	Starts an installation of a Data Vault component. Default is 1. Do not modify the default value.
INSTALL_TYPE_UPGRADE	Starts an upgrade of a Data Vault component. Default is 0. Do not modify the default value.

Property Name	Description
SELECTED_LICENSE_FILE	Absolute path and file name of the license key file.
USER_INSTALL_DIR	Directory in which to install the Data Vault component. For the Data Vault Data Archive plug-in, the installation directory must contain an instance of Data Archive. For the Data Vault Administration Tool, the installation directory must be empty.
SILENT_INSTALL	Indicates silent installation mode. Default is True. Do not modify the default value.
INSTALL_FAS	Set to True to install the Data Vault component. Set to False to skip the installation of the Data Vault component. If you set the INSTALL_FAS parameter to True, you must set the following parameters to False: <ul style="list-style-type: none"> <li>- INSTALL_ODBC</li> <li>- INSTALL_FAS_AGENT</li> <li>- INSTALL_FAS_ARCHIVE_PLUGIN</li> <li>- INSTALL_SQL_WORKSHEET</li> <li>- INSTALL_ADMIN_CONSOLE</li> </ul>
INSTALL_ODBC	Set to True to install the Data Vault ODBC component. Set to False to skip the installation of the Data Vault ODBC component. If you set the INSTALL_ODBC parameter to True, you must set the following parameters to False: <ul style="list-style-type: none"> <li>- INSTALL_FAS</li> <li>- INSTALL_FAS_AGENT</li> <li>- INSTALL_FAS_ARCHIVE_PLUGIN</li> <li>- INSTALL_SQL_WORKSHEET</li> <li>- INSTALL_ADMIN_CONSOLE</li> </ul>
INSTALL_FAS_AGENT	Set to True to install the Data Vault Agent component. Set to False to skip the installation of the Data Vault Agent component. If you set the INSTALL_FAS_AGENT parameter to True, you must set the following parameters to False: <ul style="list-style-type: none"> <li>- INSTALL_FAS</li> <li>- INSTALL_ODBC</li> <li>- INSTALL_FAS_ARCHIVE_PLUGIN</li> <li>- INSTALL_SQL_WORKSHEET</li> <li>- INSTALL_ADMIN_CONSOLE</li> </ul>
INSTALL_FAS_ARCHIVE_PLUGIN	Set to True to install the Data Vault Data Archive plug-in. Set to False to skip the installation of the Data Vault Data Archive plug-in. If you set the INSTALL_FAS_ARCHIVE_PLUGIN parameter to True, you must set the following parameters to False: <ul style="list-style-type: none"> <li>- INSTALL_FAS</li> <li>- INSTALL_ODBC</li> <li>- INSTALL_FAS_AGENT</li> <li>- INSTALL_SQL_WORKSHEET</li> <li>- INSTALL_ADMIN_CONSOLE</li> </ul> <p>You must install the Data Vault Data Archive plug-in on a machine that hosts Data Archive. Verify that Data Archive is running when you install the Data Archive plug-in.</p>

Property Name	Description
INSTALL_SQL_WORKSHEET	<p>Set to True to install the Data Vault SQL Tool. Set to False to skip the installation of the Data Vault SQL Tool.</p> <p>If you set the INSTALL_SQL_WORKSHEET parameter to True, you must set the following parameters to False:</p> <ul style="list-style-type: none"> <li>- INSTALL_FAS</li> <li>- INSTALL_ODBC</li> <li>- INSTALL_FAS_AGENT</li> <li>- INSTALL_FAS_ARCHIVE_PLUGIN</li> <li>- INSTALL_ADMIN_CONSOLE</li> </ul>
INSTALL_ADMIN_CONSOLE	<p>Set to True to install the Data Vault Administration Tool. Set to False to skip the installation of the Data Vault Administration Tool.</p> <p>If you set the INSTALL_ADMIN_CONSOLE parameter to True, you must set the following parameters to False:</p> <ul style="list-style-type: none"> <li>- INSTALL_FAS</li> <li>- INSTALL_ODBC</li> <li>- INSTALL_FAS_AGENT</li> <li>- INSTALL_FAS_ARCHIVE_PLUGIN</li> <li>- INSTALL_SQL_WORKSHEET</li> </ul>
SERVER_PORT	Port number used by the ssasql command line program and other clients such as the Data Vault SQL Tool and ODBC applications to connect to the Data Vault. Default is 8500.
SERVER_EXE_PORT	Port number used by the Data Vault Agent and the Data Vault Administration Tool to connect to the Data Vault. Default is 8600.
SERVER_TEMP_DIR	Directory where the Data Vault Service stores temporary result set files. Default is \$USER_INSTALL_DIR\$/temp.
SERVER_INDEX_DIR	Directory where the Data Vault Service stores index files when you create indexes for archived tables. Default is \$USER_INSTALL_DIR\$/index.
SERVER_LOG_DIR	Directory where the Data Vault Service stores server logs. Default is \$USER_INSTALL_DIR\$/fas_logs.
SERVER_THREADS	Do not modify the default value.
SERVER_ROWSETBUFFER	Do not modify the default value.
COMMON_TEMP_DIR	Do not modify the default value.
COMMON_LOG_DIR	Do not modify the default value.
COMMON_SHARE_DIR	Do not modify the default value.
COMMON_CRYPTOLEVEL	Do not modify the default value.
AGENT_PRIORITY	Do not modify the default value.

Property Name	Description
AGENT_LOG_DIR	Directory where the Data Vault Service stores logs generated by the Data Vault Agents. Default is \$USER_INSTALL_DIR\$/fas_agent_logs.
STARTER_LOG_DIR	Directory where the Data Vault Service stores logs generated during initialization. Default is \$USER_INSTALL_DIR\$/fas_logs.
META_AUTOSTARTUP	Do not modify the default value.
QUERY_THREADS	Number of threads used by the Data Vault Agent to process client requests to the Data Vault. Default is 2.
QUERY_MEMORY	Maximum amount of memory in megabytes to use for processing client requests to the Data Vault. The Data Vault Service allocates memory dynamically up to the maximum specified in this property. Default is 2048 MB.
QUERY_TEMP_DIR	Directory where the Data Vault Service stores temporary files. Default is \$USER_INSTALL_DIR\$/temp.
QUERY_SHARE_DIR	Directory where the Data Vault Service stores temporary files for GROUP BY and ORDER BY queries. This directory must be accessible to the Data Vault Agent. If you install multiple agents, this directory must be accessible to all agents. Default is \$USER_INSTALL_DIR\$/share.
QUERY_INDEX_DIR	Directory where the Data Vault Service stores index files when you create indexes for archived tables. Default is \$USER_INSTALL_DIR\$/index.
EXPORT_BUFFSIZE	The size (in MB) of the internal buffer used for an export operation. Default is 512.
SERVICE_LOG_DIR	Directory where the Data Vault Service stores service logs. Default is \$USER_INSTALL_DIR\$/fas_logs.
NUCLEUS_META_PORT	Port number that the Data Vault Service uses to connect to the Data Vault repository. Default is 50501.
NUCLEUS_CACHE	Maximum amount of memory that the Data Vault Service uses for caching during database operations. The cache can have a minimum of 64 megabytes and a maximum of 1024 megabytes of memory. Default is 1024 MB. If this property is set to a value that is not within the allowed range, the Data Vault Service uses the default.
FAS_CONNECTION_NAME	Name of the connection to the Data Vault Service that the installer creates. Client applications can use this connection to connect to the Data Vault Service for query requests. Default name is <i>fas</i> .

Property Name	Description
DEFAULT_USERNAME	Name of the default administrator user account. The Data Vault Administration Tool, command line program, and other client applications use this user account to connect to the Data Vault.  The installer sets the name of the user account to <i>dba</i> . You cannot change the user name during installation.
DEFAULT_PASSWORD	Password for the default administrator user account.
DEFAULT_HOST	Host name or IP address of the machine that hosts the Data Vault Service.

On Windows, you can install the Data Vault and the Data Vault Agent as Windows services. You can configure the service for automatic startup. You can also specify the user account to run the service. By default, the service runs under the LocalSystem user account. You can run the Windows service under a different user account.

You can set the following parameters to configure the Data Vault and the Data Vault Agent as Windows services:

Property	Description
INSTALL_AS_SERVICE	Indicates whether to install the Data Vault Service as a Windows service. Default is False.  Set this option to True to install the component as a Windows service. Set this property if the INSTALL_FAS or INSTALL_FAS_AGENT property is set to True.
STARTER_NO_OF_AGENTS	Number of instances of the Data Vault Agent to start immediately after the Data Vault Service starts. Default is 2.
STARTER_AUTO_START	Indicates whether to start the Windows service immediately after the machine starts. Default is False.  Set this option if the INSTALL_AS_SERVICE option is set to True.
STARTER_USE_SYSTEM_USER	Indicates whether to run the Windows service under the LocalSystem account. Default is True.  Set this option to False to run the Windows service under another user account.
STARTER_USE_OTHER_USER	Indicates whether to run the Windows service under another user account that you specify. If you do not set this option, the service runs under the LocalSystem account. Default is False.  Set this option to True to run the Windows service under another user account.
STARTER_OTHER_USERNAME	User account with which to run the Windows service. Use the following format:  <code>DomainName\UserAccount</code>  This user account must have the Act as operating system permission. Required if the STARTER_USE_OTHER_USER option is set to True.
STARTER_OTHER_USER_PASSWORD	Password for the user account that runs the Windows service.  Required if the STARTER_USE_OTHER_USER option is set to True.

4. Save the properties file with the name `SilentInput.properties`.

## Step 2. Run the Silent Installer

After you create the properties file, open a command window to start the silent installer. Use the same procedure to start a Data Vault component installation or upgrade.

1. Open a command window.
2. Go to the root of the directory where the installer files are located.
3. Verify that the directory contains the `SilentInput.properties` file that you modified.
4. Start the silent installer.
  - On Windows, run the `silentinstall.cmd` file.
  - On UNIX, run the `silentinstall.sh` file.

The silent installer runs in the background. The process can take a while.

The silent installer fails if you incorrectly configure the properties file or if the installation or upgrade directory is not accessible. If the installation or upgrade fails, view the log file named *FAS-installer.log* in the root of the directory that contains the installer files. Correct the problem and then run the silent installer again.

## CHAPTER 5

# Application Accelerator Installation

This chapter includes the following topics:

- [Application Accelerator Installation Overview, 63](#)
- [Installing the Application Accelerators in Graphical Mode, 64](#)
- [Installing the Application Accelerators in Console Mode, 65](#)

## Application Accelerator Installation Overview

Install the accelerator for the ERP application from which you want to archive data. Each ERP application has a separate application accelerator installer. You can only install the application accelerator that you are licensed for.

Install Data Archive and start the ILM application server before you install the application accelerator. When you run the installer, you provide the root directory of the Data Archive installation. The installer connects to the ILM repository to determine the port on which the ILM application server runs. The installer connects to the ILM repository and adds the application accelerator metadata.

To upgrade accelerators, follow the installation steps for the accelerator you want to upgrade.

### SAP Application Retirement

Install the Data Archive, data visualization, and Data Vault components before you install the application accelerator. When you run the installer, you provide the root directory of the Data Archive installation. The installer connects to the ILM repository to determine the ports on which the ILM application server and data visualization server run. The installer exits if any of the components are not running. The installer adds the application accelerator metadata to the ILM repository. Then, the installer connects to the data visualization server to publish the pre-packaged reports.

### Java Prerequisites

If you have Java in your environment and you want to use it, set the JAVA\_HOME environment variable.

1. Ensure JAVA\_HOME is set to the java folder on the host machine. If Java is not available on the host machine, set JAVA\_HOME to the java folder in the DA installation folder.
2. Add JAVA\_HOME/bin to the PATH.

Windows example:

```
set JAVA_HOME=<DA installation home>\java
set PATH=%JAVA_HOM%\bin;%PATH%
```

UNIX example:

```
export JAVA_HOME=<DA installation home>/java
export PATH=$JAVA_HOM/bin:$PATH
```

## Installing the Application Accelerators in Graphical Mode

You can install in graphical mode on Linux, UNIX, or Windows. When you run the installer in graphical mode, you must use a graphics display server. On UNIX, the graphics display server is typically an X Window server.

1. Go to the directory where you unzipped the accelerator file.
2. Open the installer.
  - On Microsoft Windows, open `Install.bat`.
  - On Linux or UNIX, open `Install.sh`.
3. Click **Next**.
4. Enter the path and file name of the license key file.
5. Click **Next**.
6. Enter the root installation directory of Data Archive.

The root installation directory is the directory where you installed the ILM Engine.
7. Enter the ILM repository password.

The ILM repository password is the password for the ILM repository database user or login. You configured the ILM repository password when you installed the ILM Engine and ILM repository.
8. Click **Next**.
9. Select the application version in which to install the accelerator.
10. Click **Next**.
11. The **Pre-Installation Summary** page displays the installation directory and the application accelerator that will be installed.
12. Click **Install**.

The installation begins. The **Post-Installation Summary** page indicates whether the installation completed successfully.
13. Click **Done** to complete the installation.

The installer creates a log file in the root of the directory that contains the installer files. You can view the installer log file to get more information about the tasks that are performed by the installer and to view configuration properties.

The installer creates the `SAPAccelerator.log` log file for SAP applications. The installer creates the `ILMInstaller.log` log file for all other applications.



# Installing the Application Accelerators in Console Mode

You can install the application accelerators in console mode on UNIX or Linux.

1. Use a shell command line to run the following file:

```
<Root Installation Files Directory>/install.sh
```

2. Read the introduction and press **Enter**.

3. Enter the path and file name of the license key and press **Enter**.

4. Enter the absolute path of the root installation directory of Data Archive and press **Enter**.

The root installation directory is the directory where you installed the ILM Engine and ILM repository.

5. Enter the ILM repository password and press **Enter**.

The ILM repository password is the password for the ILM repository database user or login. You configured the ILM repository password when you installed the ILM Engine and ILM repository.

6. Choose the application version in which to install the accelerators and press **Enter**.

7. Review the pre-installation summary and press **Enter**.

8. Review the post-installation summary and press **Enter** to complete the installation.

The post-installation summary indicates whether the installation completed successfully.

The installer creates a log file in the root of the directory that contains the installer files. You can view the installer log file to get more information about the tasks that are performed by the installer and to view configuration properties.

The installer creates the `SAPAccelerator.log` log file for SAP applications. The installer creates the `ILMInstaller.log` log file for all other applications.

## CHAPTER 6

# Application Retirement for Healthcare Accelerator Installation

This chapter includes the following topics:

- [Application Retirement for Healthcare Accelerator Installation Overview, 66](#)
- [Prerequisites, 66](#)
- [Installing the Accelerator in Graphical Mode, 67](#)
- [Installing the Accelerator in Console Mode, 68](#)
- [After You Install, 68](#)

## Application Retirement for Healthcare Accelerator Installation Overview

The application retirement for healthcare accelerator installer is included in the accelerator installation .zip file. On Windows, you can run the installer in graphical mode. On UNIX or Linux, you can run the installer on graphical or console mode.

## Prerequisites

Before you install the application retirement for healthcare accelerator, verify that you have the license key available. Then install Data Archive and start the ILM application server. Last, configure visualization properties and the `conf.properties` file.

Perform the following tasks before you install the accelerator:

1. Verify that you have the license key for the accelerator available. The license for the accelerator is separate from the Data Archive and Data Visualization licenses. Copy the license key file to a directory that is accessible to the user account installing the accelerator.

2. Install the Data Archive, data visualization, and Data Vault components. The installer connects to the ILM repository to determine the ports on which the ILM application server and data visualization server run.
3. Start the ILM application server and data visualization server before you run the accelerator installer. If any of the components are not running, the installation fails.
4. In the Data Archive `conf.properties` file, set the following property:  
**informia.sqlServerNVarcharMaxAndVarcharMaxToVarchar = Y**  
 For more information about the `conf.properties` file, see the *Informatica Data Archive Administrator Guide*.
5. Restart the ILM application server.
6. If you are running an upgraded environment as opposed to a new installation of Data Archive, set the following properties in `\\installationfolder\webapp\visualization\reporthome\bin\server.properties`:
  - `server.enableDynamicResource=true`
  - `server.rmserver.enable=true`
7. If you have Java in your environment and you want to use it, set the `JAVA_HOME` environment variable:
  - Ensure `JAVA_HOME` is set to the java folder on the host machine. If Java is not available on the host machine, set `JAVA_HOME` to the java folder in the DA installation folder.
  - Add `JAVA_HOME/bin` to the `PATH`.

Windows example:

```
set JAVA_HOME=<DA installation home>\java
set PATH=%JAVA_HOM%\bin;%PATH%
```

UNIX example:

```
export JAVA_HOME=<DA installation home>/java
export PATH=$JAVA_HOM/bin;$PATH
```

## Installing the Accelerator in Graphical Mode

You can install the accelerator in graphical mode on Linux, UNIX, or Windows. When you run the installer in graphical mode, you must use a graphics display server. On UNIX, the graphics display server is usually an X Window server.

1. Go to the directory where you unzipped the accelerator file.
2. To run the installer, double-click the `install.bat` file on Microsoft Windows or the `install.sh` file on Linux or UNIX.  
 The installer **Welcome** screen appears.
3. Click **Next**.
4. Enter the path and the file name of the license key file.
5. Click **Next**.
6. Enter the full path of the root installation directory of Data Archive, including the complete Windows Management Instrumentation Command-line (WMIC) if you are installing on Microsoft Windows.  
 The root installation directory is the directory where you installed the ILM Engine.
7. Enter the ILM repository password.

The ILM repository password is the password for the ILM repository database user or login. You configured the ILM repository password when you installed the ILM Engine and ILM repository.

8. Click **Next**.
9. Select the application version of the accelerator that you want to install.
10. Click **Next**.
11. Review the information on the **Pre-Installation Summary** page and then click **Install**.

The installation begins. The **Post-Installation Summary** page indicates whether the installation completed successfully.

12. Click **Done** to complete the installation.

The installer creates a log file in the root of the directory that contains the installation files. You can view the installation log file to review configuration properties and get more information about the tasks that the installer performs.

## Installing the Accelerator in Console Mode

You can install the accelerator in console mode on UNIX or Linux.

1. Use a shell command line to run the following file:

```
<Root Installation Files Directory>/install.sh
```

2. Read the introduction and press **Enter**.
3. Enter the path and name of the license key file and then press **Enter**.
4. Enter the path of the root installation directory of Data Archive and press **Enter**.  
The root installation directory is the directory where you installed the ILM Engine.
5. Enter the ILM repository password and press **Enter**.

The ILM repository password is the password for the ILM repository database user or login. You configured the ILM repository password when you installed the ILM Engine and ILM repository.

6. Choose the application version of the accelerator that you want to install and press **Enter**.
7. Review the pre-installation summary and press **Enter**.
8. Review the post-installation summary and press **Enter** to complete the installation.

The post-installation summary indicates whether the installation completed successfully.

The installer creates a log file in the root of the directory that contains the installation files. You can view the installation log file to review configuration properties and get more information about the tasks that the installer performs.

## After You Install

After you install the accelerator, you must move any external attachments from the healthcare application source system to the following location within the accelerator installation folder: `\webapp\visualization\dhtmljsp\doc\`

You can move the attachments manually or run the move external attachments standalone job. For more information on the standalone job, see the *Informatica Data Archive User Guide*.

## CHAPTER 7

# MongoDB Accelerator Installation

This chapter includes the following topics:

- [MongoDB Accelerator Installation Overview, 69](#)
- [Installing the MongoDB Accelerator in Graphical Mode, 70](#)
- [Installing the MongoDB Accelerator in Console Mode, 70](#)
- [After You Install, 71](#)

## MongoDB Accelerator Installation Overview

The MongoDB accelerator installer is included in the accelerator installation .zip file. On Windows, you can run the installer in graphical mode. On UNIX or Linux, you can run the installer on graphical or console mode.

Run the installer after you install or upgrade Data Archive. When you run the installer, you enter the license key for the accelerator and select the Data Archive installation directory.

### Java Prerequisites

If you have Java in your environment and you want to use it, set the JAVA\_HOME environment variable.

1. Ensure JAVA\_HOME is set to the java folder on the host machine. If Java is not available on the host machine, set JAVA\_HOME to the java folder in the DA installation folder.
2. Add JAVA\_HOME/bin to the PATH.

Windows example:

```
set JAVA_HOME=<DA installation home>\java
set PATH=%JAVA_HOM%\bin;%PATH%
```

UNIX example:

```
export JAVA_HOME=<DA installation home>/java
export PATH=$JAVA_HOM/bin;$PATH
```

# Installing the MongoDB Accelerator in Graphical Mode

You can install the accelerator in graphical mode on Linux, UNIX, or Windows. When you run the installer in graphical mode, you must use a graphics display server. On UNIX, the graphics display server is usually an X Window server.

1. Go to the directory where you unzipped the accelerator file.
2. To run the installer, double-click the `install.bat` file on Microsoft Windows or the `install.sh` file on Linux or UNIX.  
The installer **Welcome** screen appears.
3. Click **Next**.
4. Enter the path and the file name of the license key file.
5. Click **Next**.
6. Enter the full path of the root installation directory of Data Archive, including the complete WMIC if you are installing on Microsoft Windows.  
The root installation directory is the directory where you installed the ILM Engine.
7. Click **Next**.
8. Review the information on the **Pre-Installation Summary** page and click **Install**.
9. Click **Next**.
10. Review the information on the **Pre-Installation Summary** page and then click **Install**.  
The installation begins. The **Post-Installation Summary** page indicates whether the installation completed successfully.
11. Click **Done** to complete the installation.

The installer creates a log file in the root of the directory that contains the installation files. You can view the installation log file to review configuration properties and get more information about the tasks that the installer performs.

# Installing the MongoDB Accelerator in Console Mode

You can install the accelerator in console mode on UNIX or Linux.

1. Use a shell command line to run the following file:  

```
<Root Installation Files Directory>/install.sh
```
2. Read the introduction and press **Enter**.
3. Enter the path and name of the license key file and then press **Enter**.
4. Enter the path of the root installation directory of Data Archive and press **Enter**.  
The root installation directory is the directory where you installed the ILM Engine.
5. Review the pre-installation summary and press **Enter**.
6. Review the post-installation summary and press **Enter** to complete the installation.  
The post-installation summary indicates whether the installation completed successfully.

The installer creates a log file in the root of the directory that contains the installation files. You can view the installation log file to review configuration properties and get more information about the tasks that the installer performs.

## After You Install

After you install the accelerator, restart the ILM application server to create the MongoDB connections in Data Archive.

To create a MongoDB connection in the Enterprise Data Manager, perform the following steps:

1. Download the latest `EDM.zip` file.
2. Close the existing Enterprise Data Manager instance.
3. Run the latest `edm.bat` file.

## CHAPTER 8

# Salesforce Accelerator Installation

This chapter includes the following topics:

- [Salesforce Accelerator Installation Overview, 72](#)
- [Installing the Accelerator in Graphical Mode, 73](#)
- [Installing the Accelerator in Console Mode, 73](#)
- [After You Install, 74](#)

## Salesforce Accelerator Installation Overview

The Salesforce accelerator installer is included in the accelerator installation .zip file. On Windows, you can run the installer in graphical mode. On UNIX or Linux, you can run the installer on graphical or console mode.

Run the installer after you install or upgrade Data Archive. When you run the installer, you enter the license key for the accelerator and select the Data Archive installation directory. You also enter the ILM repository password.

### Java Prerequisites

If you have Java in your environment and you want to use it, set the JAVA\_HOME environment variable.

1. Ensure JAVA\_HOME is set to the java folder on the host machine. If Java is not available on the host machine, set JAVA\_HOME to the java folder in the DA installation folder.
2. Add JAVA\_HOME/bin to the PATH.

Windows example:

```
set JAVA_HOME=<DA installation home>\java
set PATH=%JAVA_HOME%\bin;%PATH%
```

UNIX example:

```
export JAVA_HOME=<DA installation home>/java
export PATH=$JAVA_HOME/bin:$PATH
```



# Installing the Accelerator in Graphical Mode

You can install the accelerator in graphical mode on Linux, UNIX, or Windows. When you run the installer in graphical mode, you must use a graphics display server. On UNIX, the graphics display server is usually an X Window server.

1. Go to the directory where you unzipped the accelerator file.
2. To run the installer, double-click the `install.bat` file on Microsoft Windows or the `install.sh` file on Linux or UNIX.

The installer **Welcome** screen appears.

3. Click **Next**.
4. Enter the path and the file name of the license key file.
5. Click **Next**.
6. Enter the full path of the root installation directory of Data Archive, including the complete WMIC if you are installing on Microsoft Windows.

The root installation directory is the directory where you installed the ILM Engine.

7. Enter the ILM repository password.
8. Click **Next**.
9. Select the application version of the accelerator that you want to install.
10. Click **Next**.
11. Review the information on the **Pre-Installation Summary** page and then click **Install**.

The installation begins. The **Post-Installation Summary** page indicates whether the installation completed successfully.

12. Click **Done** to complete the installation.

The installer creates a log file in the root of the directory that contains the installation files. You can view the installation log file to review configuration properties and get more information about the tasks that the installer performs.

# Installing the Accelerator in Console Mode

You can install the accelerator in console mode on UNIX or Linux.

1. Use a shell command line to run the following file:  

```
<Root Installation Files Directory>/install.sh
```
2. Read the introduction and press **Enter**.
3. Enter the path and name of the license key file and then press **Enter**.
4. Enter the path of the root installation directory of Data Archive and press **Enter**.

The root installation directory is the directory where you installed the ILM Engine.

5. Enter the ILM repository password and press **Enter**.

The ILM repository password is the password for the ILM repository database user or login. You configured the ILM repository password when you installed the ILM Engine and ILM repository.

6. Choose the application version of the accelerator that you want to install and press **Enter**.
7. Review the pre-installation summary and press **Enter**.
8. Review the post-installation summary and press **Enter** to complete the installation.

The post-installation summary indicates whether the installation completed successfully.

The installer creates a log file in the root of the directory that contains the installation files. You can view the installation log file to review configuration properties and get more information about the tasks that the installer performs.

## After You Install

After you install the accelerator, restart the ILM application server to create the Salesforce connections in Data Archive.

To create a Salesforce connection in the Enterprise Data Manager,

1. Download the latest `RunEDM.jnlp` file.
2. Close the existing Enterprise Data Manager instance.
3. Run the latest `.jnlp` file.

## CHAPTER 9

# After You Install

This chapter includes the following topics:

- [Client Machine Requirements, 75](#)
- [Starting the ILM Application Server, 76](#)
- [Starting the Data Vault Components, 76](#)
- [Configuring Memory Settings on a 64-bit Computer, 80](#)
- [Configuring Embedded Tomcat for HTTPS, 80](#)
- [Registering Services as Windows Services, 81](#)
- [Configuring Data Archive, 82](#)
- [Setting up SAP Retirement, 82](#)

## Client Machine Requirements

Review the following client machine requirements and configure browser settings on machines that accesses Data Archive.

Machines that access Data Archive must meet certain requirements.

### Java Requirements

Enterprise Data Manager is available as an `edm.bat` file inside the `webapp/edm` folder under the Data Archive home directory. The `edm` folder also contains a supported Azul JRE for Windows. Copy the `edm` folder to the Windows client. To run Enterprise Data Manager, double-click `edm.bat`.

Set `JAVA_HOME` to the Azul JRE inside the `edm` folder. Use it to run the `edm.bat` file.

If the client machine does not have JDK installed, Data Visualization Designer uses the Azul JDK inside the Designer folder.

### Web Browser Requirements

Supported web browsers must be able to run JavaScripts. They must also allow popup windows.

# Starting the ILM Application Server

The web application deploy directory contains scripts to start and stop the ILM application server. The script names depend on the operating system.

- ▶ To start and stop the ILM application server, run one of the following files or scripts:
  - Windows. Run batch files `startApplimation.bat` and `stopApplimation.bat`.
  - UNIX or Linux. Run shell scripts `startApplimation.sh` and `stopApplimation.sh`.

You can start or stop the ILM application server in the background. You can also abort the ILM application server if it stops responding. To check the status of the ILM process, run the following command:

```
ps -ef | grep informia
```

## Logging In to Data Archive

After you start the ILM application server, you can access Data Archive.

Use the following URL to access the user interface:

```
http://hostname:portnumber
```

During installation, a default administrator user account is created. Both the login ID and the password are `amadmin`.

# Starting the Data Vault Components

You can use `ssa_starter` startup program created during installation to start and stop the Data Vault components, and to restart the components if they fail.

On UNIX, the `ssa_starter` program runs as a daemon. On Windows, you can configure the `ssa_starter` program as a Windows service.

## Before You Start the Data Vault Components

Before you start the Data Vault components, you might have to set the Data Vault environment variables.

If you have Windows and you plan to start the Data Vault components through Windows services, you do not have to set the Data Vault environmental variables.

If you plan to start the Data Vault components in one of the following ways, you must set the Data Vault environment variables:

- Use an operating system other than Windows.
- Use the Windows command prompt.

To set the Data Vault environment variables, run the `ssaenv` file that is located in the Data Vault installation directory. The `ssaenv` file is a pre-configured script file that contains commands that set the Data Vault environment variables.

To run the `ssaenv` file, use one of the following commands:

### On an operating system other than Windows

Use the following command: `source ssaenv.sh`

**Note:** If you are using a C shell environment, use the following command: `source ssaenv.csh`

### On a Windows operating system through the command prompt

Use the following command: `ssaenv.cmd`

## ssa\_starter Syntax

The `ssa_starter` options you can use depend on the platform where you install the Data Vault.

`ssa_starter option`

The following table describes syntax options for Windows and UNIX:

Option	Description
-i	Installs the <code>ssa_starter</code> service. Only for Windows.
-u	Uninstalls the <code>ssa_starter</code> service. Only for Windows.
-r	Runs <code>ssa_starter</code> manually, not as a service.
-s	Sends SIGHUP to the running daemon, which causes it to re-read the <code>ssa.ini</code> file. This option should be used after making changes to the configuration. Only for UNIX.
-o	Sends the log to the standard output stream, which is usually the console.
-h	Displays the online help.

## Startup Configuration Parameters

The `ssa_starter` startup program uses configuration settings in the [STARTER] section of the `ssa.ini` file.

The following table describes the parameters used by the startup service:

Parameter	Description
SERVER_CMD	The command to start the Data Vault Service. Default is <code>ssaserver</code> .
AGENT_CMD	The command to start the Data Vault Agent. Default is <code>ssaagent</code> . Do not include the <code>-u</code> parameter to specify a numeric ID for the agent process. The startup service assigns an agent ID.
AGENT_COUNT	The number of Data Vault Agents processes to start. Default is 2.
LOGDIR	The directory where the log files will be written. On UNIX, the daemon log is named <code>ssa_starter</code> . On Windows the service activities are logged by the operating system, which can be viewed through the Event Viewer.
AGENT_CONTROL	Enables (1) or disables (0) automatic restart if the Data Vault Agent fails. Default is 1.
SERVER_CONTROL	Enables (1) or disables (0) automatic restart if the Data Vault Service fails. Default is 1.

Parameter	Description
USER	<p>UNIX only. The user ID under which all processes will be started by the ssa_starter daemon. It is usually important to set this parameter, since the default is the root user, which can cause problems. For example, if a process running as root creates a file, only another root process can access that file.</p> <p>This parameter can also be set using the SSA_STARTER_USER environment variable. If both the ssa.ini file and the environment variable define the user ID, the environment variable takes precedence.</p>
VERBOSE	<p>The level of detail for the messages written to the log files. The following are the possible options:</p> <ul style="list-style-type: none"> <li>- 0 : Includes all error messages and the most important messages</li> <li>- 1 : Level 0 plus more detailed messages</li> <li>- 2 : Level 1 plus system trace information</li> </ul> <p>Default is 2.</p>
EXE[0-9]	<p>These 10 optional parameters (EXE0, EXE1, EXE2, ..., EXE9) refer to custom commands, scripts, or executables that will run in conjunction with Data Vault Service on startup. Note that the numbering of the parameters has no relationship to the order in which they are processed. These parameters are run asynchronously, so there is no guarantee about the execution order.</p>

The ssa\_starter program reads the [STARTER] section in the ssa.ini file to determine the settings at initialization. The [STARTER] section in the ssa.ini file must specify at least the following parameters:

- SERVER\_CMD. Contains the command to start the Data Vault Service.
- AGENT\_CMD. Contains the command to start the Data Vault Agent.

The AGENT\_COUNT parameter indicates the number of agents to start and must be set to a value of 1 or higher, otherwise no agent will be started.

The AUTOSTARTUP parameter must be set to 1 (enabled) in the [META] section of the ssa.ini file so that the startup service or daemon works properly. This allows the startup service to start the Data Vault repository database before the Data Vault Service. A related parameter, STARTUPCOMMAND, which defines the command line for starting the Data Vault repository database, must also be configured in the same section of the ssa.ini file. If the Data Vault repository database is not on the local machine, the STARTUPHOST parameter must specify the name of the remote computer where the Data Vault repository database is located.

If the Data Vault server shuts down unexpectedly, enabling AUTOSTARTUP might prevent it from restarting. This is because after a server shuts down unexpectedly, the child metadata process remains running, so that the port is busy.

To prevent this behavior, you can also manage the metadata server with ssa\_starter and the EXE commands. If you do not enable AUTOSTARTUP, you must add the following EXE parameters in the [STARTER] section of the ssa.ini file:

For UNIX:

```
EXE0=fb_inet_server -m
EXE0_CONTROL=1
```

For Microsoft Windows:

```
EXE0=fb_inet_server -a
EXE0_CONTROL=1
```

These parameters allow `ssa_starter` to manage the metadata server process when the `AUTOSTARTUP` option is set to 0. The name of the metadata server process is `fb_inet_server.exe`. Formerly, this process, which runs on the application server, was called `ssaeng.exe` on Microsoft Windows and `ssaeng` on Linux.

On UNIX, if any changes are made in the `ssa.ini` file to parameters related to the Data Vault Service daemon, `ssa_starter` can be made to read the changes in the `ssa.ini` file using the `ssa_starter -s` command. On Windows, the service can be made to re-read the configuration by stopping, then restarting the service.

## Starting the Data Vault Service

You can start the Data Vault Service separately. If you start the components separately, start the Data Vault Service before you start the agent.

Ensure that the configuration settings for Data Vault Service are set properly in the `ssa.ini` file. The startup parameters in the `[META]` section must point to the Data Vault repository database. You must start the Data Vault Service before you start the agent.

Start Data Vault Service with the following command:

```
ssaserver
```

On UNIX, you can use the `&` option to run the Data Vault Service in the background.

If the Data Vault Service has successfully connected to the Data Vault repository database, the following text will be displayed at the console:

```
META starting up.....ok
COM starting up...ok
EXEC starting up...ok
SSA Server successfully started.
```

## Starting the Data Vault Agent

You can start each Data Vault Agent separately. The Data Vault Service must be running when the agent starts. If you start the components separately, start the Data Vault Service before you start the agent.

When the Data Vault Agent process starts, it reads the local `ssa.ini` file and uses information in the `[SERVER]` section to connect to the Data Vault Service. If an agent is started on a remote machine, there must be an `ssa.ini` file on that machine containing the same `HOST` and `EXEPORT` parameters and values as the `ssa.ini` file on the machine that hosts the Data Vault Service. Parameters that are specific to the agent can also be found in the `[AGENT]` section of the `ssa.ini` file.

You can start the Data Vault Agent with the following command:

```
ssaagent [ -u AID ][ -p priority ]
```

where:

- `AID` is an optional user-defined numeric ID for the `ssaagent` process. `Ssaagent` processes viewed through the Data Vault Service administration command line program are identified by this Agent ID ("AID"), or if the AID was not set, by the operating system process ID (PID). Each `ssaagent` process started on the same machine must be given a unique AID value. A space must separate the `-u` flag from its value.
- `priority` specifies an optional priority level for the `ssaagent` process. This must be a value from 0 to 10 inclusive, where a larger number means higher priority. A priority level of 0 effectively "freezes" the agent, making it unavailable for task execution after it completes its current task (if applicable). A priority level of 1 reserves the `ssaagent` process for administrator tasks, such as compressed data file registration. A space must separate the `-p` flag from its value.

You can start as many Data Vault Agents as required. At minimum, there must be one Data Vault Agent running. On UNIX, you can use the `&` option to run the agent in the background.

If the agent starts up successfully, it displays a message similar to the following (server names and port numbers will vary):

```
New connection 1 to the <Host: ALPHA1, PN: 6500> has been established
LOG>Info : The agent: <host: alpha1, AID: 1368>, priority: 10 was successfully registered
```

## Configuring Memory Settings on a 64-bit Computer

If you install ILM products on a 64-bit machine, you can allocate additional memory for the ILM Java Virtual Machine (JVM). To allocate additional memory, update the maximum heap size in the startApplimation batch file or script.

The default heap sizes for the ILM JVM are as follows:

- Minimum heap size (-Xms) = 512 MB
- Maximum heap size (-Xmx) = 1 GB

The default heap sizes are adequate for most installations on 32-bit machines. If you install ILM products on a 64-bit machine and notice performance issues, you might want to increase the maximum heap size for the ILM JVM. Set the maximum heap size to a value of 3 GB or less.

To configure the memory settings, update the following command in the startApplimation batch file or script:

```
$JAVA_HOME/bin/java -Dfile.encoding=UTF-8 -Dapp.home=$SEARCHDIR -Djava.awt.headless=true -
Xms512m - Xmx3072m -jar ./lib/informia-server-6.2.jar start
```

## Configuring Embedded Tomcat for HTTPS

You can configure the embedded Tomcat server to use HTTPS connections.

1. Create a certificate key store on the computer running Tomcat.

Run the following command:

```
keytool -genkey -alias <Alias Name> -keyalg RSA - keystore /path/to/my/keystore
```

2. Uncomment the following properties in the conf.properties file:

- informia.sslEnabled
- informia.sslKeystoreFile
- informia.sslKeystorePass
- informia.isKeyStorePassEncrypted

3. Open encryptPassword.sh in a UNIX environment or encryptPassword.bat in a Windows environment. This file is located in the same directory as the conf.properties file.

4. Paste the keystore password in the encryptPassword file.

5. Save and run the encryptPassword file to encrypt the keystore password.

The run-encryptPassword task returns an encrypted password.

6. Copy the encrypted password and paste in the value section of the informia.sslKeystorePass property.  
informia.sslKeystorePass=<encrypted keystore password>



7. Assign the following values to the uncommented properties:
  - `informia.sslEnabled=Y`
  - `informia.sslKeystoreFile=<path of the keystore file>`
  - `informia.isKeyStorePassEncrypted=true`
8. Restart `startApplimation.sh` or `startApplimation.bat`.

## Registering Services as Windows Services

You can register the Archive Service and the Data Vault Service for External Attachments with Windows. After you register the service, you can start or stop the service as a Windows service.

### Registering the Archive Service

Register the Archive Service as a Windows service on the computer where you installed the Archive Service.

1. Go to the ILM installation directory.
2. Double-click the `RegisterArchiveService.bat` file.

The Archive Service appears as a Windows service in the Services Microsoft Management Console (MMC) snap-in.

**Note:** To unregister the service, double-click the `UnregisterArchiveService.bat` file.

### Registering the Archive Service with SSL Enabled

If you start Data Archive as the Archive Service, you must reregister the Archive Service after you enable SSL. To reregister the Archive Service, perform the following steps:

1. Unregister the existing Windows service using `unregisterArchiveservice.bat`, located in `$ILMFOLDER/UnregArchiveService.bat`.
2. Open `RegArchiveService.bat` and add the truststore and password.  
For example: `++JvmOptions=-Djavax.net.ssl.trustStore=XXX.jks ++JvmOptions=-Djavax.net.ssl.trustStorePassword=XXXXX`
3. Register the service again with `RegArchiveService.bat`.
4. Restart the Archive service.

### Registering the Data Vault Service for External Attachments

Register the Data Vault Service for External Attachments as a Windows service on the computer where the Data Vault Service for External Attachments component is installed.

1. Go to the ILM installation directory.
2. Double-click the `RegisterFASAservice.bat` file.

The Data Vault Service for External Attachments appears as a Windows service in the Services Microsoft Management Console (MMC) snap-in.

**Note:** To unregister the service, double-click the `UnregisterFASAService.bat` file.

# Configuring Data Archive

You must configure Data Archive before you can run an archive or retirement project, or partition your source database.

To configure Data Archive, you perform the following tasks:

1. Set up the required database users with privileges.
2. Configure the properties in the `conf.properties` file.
3. Configure the properties in the system profile.
4. Create the source and target connections.

For more information about configuring Data Archive, see the *Informatica Data Archive Administrator Guide*.

# Setting up SAP Retirement

If you plan to retire an SAP application, you must set up SAP application retirement.

For more information about upgrading Data Vault, see [“Setting Up SAP Application Retirement” on page 115](#).

# CHAPTER 10

## Data Archive Upgrade

This chapter includes the following topics:

- [Data Archive Upgrade Overview, 83](#)
- [Before You Upgrade, 84](#)
- [Upgrading Data Archive in Graphical Mode, 84](#)
- [Upgrading Data Archive in Console Mode, 85](#)
- [Upgrading Data Archive in Silent Mode, 86](#)
- [After You Upgrade Data Archive, 86](#)
- [Reverting to a Previous Version, 87](#)

### Data Archive Upgrade Overview

Use the Data Archive installer to upgrade Data Archive.

When you upgrade to the current release, you upgrade Data Archive and install the accelerators in the current repository. You cannot upgrade the repository to a different database.

The upgrade includes the current hotfix level. Hotfixes are cumulative. You can upgrade directly to the latest hotfix.

When you upgrade Data Archive, the installer also upgrades Data Vault Loader and Data Discovery if they are installed in the same directory as Data Archive. If not, then you must upgrade Data Vault Loader and Data Discovery separately after you upgrade Data Archive. If you installed Data Vault Loader and Data Discovery on the Data Vault server or any other server, run the installer to upgrade the component on that server.

On Windows, you can run the Data Archive installer in graphical or silent mode. On UNIX, you can run the installer on graphical, console, or silent mode. The silent mode upgrade uses a properties file to determine the upgrade options.

The upgrade procedure depends on the version that you upgrade from.

The following table describes the upgrade path from previous versions:

Data Archive Version You Upgrade From	Upgrade Steps to the Current Data Archive Version
6.5, 6.5HF1	Upgrade to the current version.
6.4.4	Upgrade to 6.5.

Data Archive Version You Upgrade From	Upgrade Steps to the Current Data Archive Version
6.4.3HF1	Upgrade to 6.4.4.
6.4.3	Upgrade to 6.4.3HF1.
6.4, 6.4HF1, 6.4HF2	Upgrade to 6.4.3.

After you upgrade to the current release, install the accelerators.

## Before You Upgrade

Before you upgrade to the current version of Data Archive, perform the following tasks:

- Read the release notes for information about known and fixed limitations for the release.
- Verify that you have read and write privileges on the directory where the `ILM_HOME` folder exists. If you do not have read and write privileges on this directory, the upgrade fails.
- Create a backup of the ILM repository database and the `ILM_HOME` folder. If the upgrade fails, you must restore the backup before you try to upgrade again.
- Stop the ILM application server and end all ILM services.
- Optionally, delete the `work` folder from the `ILM_HOME` directory.
- Extract the installer files from the compressed installation file:
 

```
Informatica_ILM_<release><hotfix>.zip
```

 The installer files include the Data Archive installer.
- If you use the Application Retirement for Healthcare accelerator, verify that the catalog that exists in `ILM_HEALTHCARE\<ARCHIVE_FOLDER_NAME>` and the catalog deployed on the JReport Server are the same. If not, download the latest catalog from the JReport Server through JReport Designer and place the catalog inside `ILM_HEALTHCARE\<ARCHIVE_FOLDER_NAME>` before you upgrade.
- When you upgrade to version 6.5.1 on Oracle database, you might encounter the following error: `ORA-01000: maximum open cursors exceeded`. To avoid the error, set the Maximum open cursors value to 1000 or higher in the `AMHOME` database.

## Upgrading Data Archive in Graphical Mode

You can upgrade in graphical mode on Linux, UNIX, and Windows.

To upgrade in graphical mode on UNIX and Linux, you need the X Window client and server software.

1. Extract the contents of the `Informatica_ILM_<release><hotfix>.zip` file.
2. With administrator privileges, run one of the following commands:
  - On Windows operating systems, run `install.cmd`.
  - On UNIX based operating systems, run `install.sh`.

The **Data Archive Installer** dialog appears.

3. Click **Next**.

4. Enter the path of the existing Data Archive installation directory. For example, `C:\ILM`

5. Click **Next**.

The **Pre-installation Summary** displays the installation directory and the component that you selected to upgrade. If the previous version of the component is not in the installation directory you provided, you receive an error message.

6. Click **Install**.

The **Post-Installation Summary** window indicates whether the upgrade completed successfully.

7. Click **Done** to complete the upgrade.

The installer copies existing customizations to the web directory. Customizations include `conf.properties`, custom stylesheets, and `custom.xml` for custom implementations of the adapters. The installer produces a log file about the tasks and errors that occurred during the upgrade. You can find the log file, `ILMInstaller.log`, in the installation directory.

8. If the Data Vault Loader and Data Discovery component is installed on the Data Vault server or another server, run the installer again to upgrade the component.
9. Install the accelerators. For more information, see ["Installing the Application Accelerators in Graphical Mode" on page 64](#).

## Upgrading Data Archive in Console Mode

You can upgrade in console mode on UNIX or Linux.

1. From a command prompt, navigate to the installation directory where you extracted the files from `Informatica_ILM_<release><hotfix>.zip`.

2. Run the `install.sh` on UNIX based operating systems.

The **Welcome** text appears.

3. Press ENTER.

4. Enter the path of the existing Data Archive installation directory. For example, `C:\ILM`

5. Press ENTER.

The **Pre-installation Summary** displays the installation directory and the component that you selected to upgrade. If the previous version of the component is not in the installation directory you provided, you receive an error message.

6. Press Y to confirm the installation location.

7. Press ENTER to start the installation.

The **Post-Installation Summary** indicates whether the upgrade completed successfully.

The installer copies existing customizations to the web directory. Customizations include `conf.properties`, custom stylesheets, and `custom.xml` for custom implementations of the adapters.

The installer produces a log file about the tasks and errors that occurred during the upgrade. You can find the log file, `ILMInstaller.log`, in the installation directory.

8. If the Data Vault Loader and Data Discovery component is installed on the Data Vault server or another server, run the installer again to upgrade the component.

9. Install the accelerators. For more information, see [“Installing the Application Accelerators in Graphical Mode” on page 64.](#)

## Upgrading Data Archive in Silent Mode

To upgrade Data Archive without user interaction, run the installer in silent mode. You can upgrade in silent mode on Linux, UNIX, and Windows.

To upgrade in silent mode, update the `SilentInstall.properties` file, and then run the installer with the properties file.

1. Copy the installation files to the hard disk on the machine where you plan to upgrade Data Archive.  
If you upgrade on a remote machine, verify that you can access and create files on the remote machine.
2. Locate the `SilentInstall.properties` file.
3. Use a text editor to open the file and change the value of the `USER_INSTALL_DIR` property.  
Enter the path of the existing Data Archive installation directory.
4. Run the installer with the `SilentInstall.properties` file.

Use the following syntax:

- Windows: `install.cmd -i silent -f SilentInstall.properties`
- UNIX: `sh install.sh -i silent -f SilentInstall.properties`

If the silent installer properties file is in another directory, specify the full file path to the properties file. For example:

```
install.cmd -i silent -f C:\ILMInstaller\SilentInstall.properties
```

5. If the Data Vault Loader and Data Discovery component is installed on the Data Vault server or another server, run the installer again to upgrade the component.

## After You Upgrade Data Archive

Before you use the new version of Data Archive, perform the post-upgrade tasks.

1. If you use Data Vault to archive or retire data, upgrade the Data Vault Service and the Data Vault Data Archive Plug-in.  
For more information about upgrading Data Vault, see [Chapter 11, “Data Vault Upgrade” on page 88.](#)
2. If you previously used Data Archive to archive Salesforce data, you must install version 6.5.1 of the Salesforce Accelerator after you upgrade to Data Archive version 6.5.1. This ensures that you get the latest Salesforce JAR.  
For more information, see [“Salesforce Accelerator Installation Overview” on page 72.](#)
3. Start the ILM application server.
4. If you previously used the create materialized views standalone job, for example to create views for Patient Information reports, run the create materialized views standalone job on the existing archive folder. You must run the create materialized view job again after you upgrade to ensure that the aggregation calculation .sct files for the views are in the correct folder.

# Reverting to a Previous Version

If the upgrade fails and you want to revert to the previous version, first complete the following tasks:

1. Delete all of the files in the USER\_INSTALL\_DIR directory except for the backup zip file.
2. Unzip the backup zip file.
3. Delete the backup zip file.

You can then re-attempt the upgrade.

# CHAPTER 11

## Data Vault Upgrade

This chapter includes the following topics:

- [Data Vault Upgrade Overview, 88](#)
- [Before You Upgrade a Data Vault Component, 89](#)
- [Upgrading in Graphical Mode , 90](#)
- [Upgrading in Console Mode, 91](#)
- [Upgrading in Silent Mode, 91](#)
- [Troubleshooting Data Vault Upgrade, 93](#)
- [After You Upgrade, 93](#)
- [Reverting an Upgrade, 95](#)

### Data Vault Upgrade Overview

Run the Data Vault installer to upgrade a Data Vault component. Use the same procedure to upgrade each component.

When you upgrade, you must upgrade the following Data Vault components:

- Data Vault Service
- Data Vault Agent
- Data Vault ODBC driver
- Data Vault Data Archive Plug-in
- Data Vault Administration Tool and SQL Tool

On Windows, you can run the Data Vault installer in graphical or silent mode. On UNIX, you can run the installer on graphical, console, or silent mode. The silent mode upgrade uses a properties file to determine the upgrade options.

Before the installer starts the upgrade process, the installer creates a zip file of the upgrade directory. If you experience a problem with the upgrade, you can revert back to the previous version.

The upgrade updates the component files and libraries to the new version but keeps the configuration settings from the previous version. The upgrade process does not affect a Data Vault in external storage. After you upgrade, you can access the Data Vault in an external storage without any changes.

You must upgrade all components to the same version. The Data Vault does not work with different versions of the components. If the product version that is currently installed cannot be upgraded to the current version, you must first upgrade to a supported version.



The following table describes the product versions from which you can upgrade:

Data Vault Version You Upgrade From	Upgrade Steps to the Current Version
6.5, 6.5 HF1	Upgrade to the current version.
6.4.4	Upgrade to 6.5.
6.4.3, 6.4.3HF1	Upgrade to 6.4.4.
6.4, 6.4HF1, 6.4HF2	Upgrade to Data Vault 6.4.3.

## Before You Upgrade a Data Vault Component

Complete the upgrade prerequisites before you upgrade the Data Vault components.

Before you upgrade a Data Vault component, complete the following tasks:

1. If you plan to upgrade on a Microsoft Windows machine, verify that you have Administrator privileges.
2. Upgrade the following Visual C++ package according to your Windows installation:

### 64-bit

On 64-bit Microsoft Windows installations, upgrade to the following Microsoft Visual C++ Redistributable Packages for Visual Studio 2019:

- Microsoft Visual C++ Redistributable Package for Visual Studio 2019 (64-bit).
- Microsoft Visual C++ Redistributable Package for Visual Studio 2019(32-bit).

### 32-bit

On 32-bit Microsoft Windows installations, upgrade to Microsoft Visual C++ Redistributable Package for Visual Studio 2019 (32-bit).

Verify that you have the correct package and service pack. Data Vault does not work with other versions of Visual C++.

3. If the version of RHEL 8 server libraries is incompatible with the OpenSSL version that Data Vault uses, you might encounter a symbol lookup error. On RHEL 8 machines, build Curl 1.1.1k libraries and export the path to the LD\_LIBRARY\_PATH environment variable. Restart the Data Archive and Data Vault servers to update the change.
4. On Linux and SUSE Linux Enterprise servers, if not already installed, install glibc-locale-base-32bit to allow 32-bit components of Data Vault to work.
5. Verify the amount of free disk space. The free disk space must be 10 times the size of the `meta.n00` file. Otherwise, the upgrade will fail.
6. Complete all Data Vault Loader jobs to ensure that all data are loaded to the Data Vault before you start the upgrade process.
7. Stop the ILM application server and end all ILM services.
8. Stop the Data Vault components. If you run Data Vault as a Microsoft Windows service, stop the service.
9. Verify that the user account you use to run the installer has read and write privileges to the directory of the Data Vault component that you plan to upgrade. The installer makes a backup copy of the directory before it starts the upgrade process. If you do not have read and write privileges to the directory, the upgrade can fail.

10. Copy the Data Vault installer files to the machine that hosts the Data Vault component that you plan to upgrade.
11. Check the metadata consistency.

## Upgrading in Graphical Mode

You can upgrade the Data Vault components in graphical mode on Windows and UNIX.

On UNIX, the graphical mode upgrade requires an X Window server. Complete the procedure for each Data Vault component. You must upgrade each Data Vault component separately.

1. Log in to the machine with a system user account.
2. Close all other applications.
3. Begin the installation.
  - On Windows, run `install.cmd` from the root directory.

**Note:** On Windows 2012, right-click the command prompt icon and open the command prompt window using "Run As Administrator." Navigate to the installer location and run `install.cmd` from this command prompt window.
  - On UNIX, use a shell command line to run `install.sh` from the root directory. If you do not have an X Window server, the installer runs in console mode.
4. On the **Introduction** page, read the instructions and click **Next**.
5. On the **Installation Type** page, select **Upgrade a Data Vault component** and click **Next**.
6. On the **Upgrade Directory** page, enter the absolute path for the directory of the Data Vault component to upgrade, or click **Choose** to select the directory.

When you upgrade the Data Vault Data Archive plug-in, specify the directory that contains the instance of Data Archive where the plug-in is installed.

When you upgrade other components, specify the directory that contains the Data Vault component that you want to upgrade.

7. Click **Next**.

The installer verifies the component files in the specified directory and determines which Data Vault component to upgrade.
8. On the **Upgrade Summary** page, review the upgrade information and click **Install** to continue.

The installer creates a zip file of the specified Data Vault component directory before it starts the upgrade. Then the installer copies the new version of the component files to the directory and overwrites the previous version.

After the upgrade process completes, the **Upgrade Complete** page indicates whether the upgrade completed successfully.

9. Click **Done**.

The installer creates a log file named `FAS-installer.log` in the root of the directory that contains the installer files. You can view the installer log file to get more information about the status of the upgrade and the tasks that are performed by the installer.

# Upgrading in Console Mode

You can upgrade a Data Vault component in console mode on UNIX. Complete the procedure for each Data Vault component. You must upgrade each Data Vault component separately.

1. Log in to the machine with a system user account.
2. Close all other applications.
3. On a shell command line, run the `install.sh` file from the root of the directory where the installation files are located.  
The **Introduction** section appears.
4. Press ENTER to continue.  
The **Installation Type** section appears.
5. Press 2 to upgrade a Data Vault component and press Enter.  
The **Upgrade Directory** section appears.
6. Type the absolute path for the directory of the Data Vault component that you want to upgrade.  
When you upgrade the Data Vault Data Archive plug-in, specify the directory that contains the instance of Data Archive where the plug-in is installed.  
When you upgrade other components, specify the directory that contains the Data Vault component that you want to upgrade.
7. Press Y to confirm the upgrade directory.  
If the Data Vault component is running, the installer displays a message to stop the component before continuing the upgrade. Verify that the Data Vault component is not running and press Enter to continue. The installer verifies the component files in the specified directory and determines which Data Vault component to upgrade.  
The **Upgrade Summary** section appears.
8. Review the upgrade summary and press Enter to continue.  
The installer creates a zip file of the specified Data Vault component directory before it starts the upgrade. Then the installer copies the new version of the component files to the directory and overwrites the previous version.  
The **Upgrade Complete** section appears.
9. Press Enter to exit the installer.  
The installer creates a log file named `FAS-installer.log` in the root of the directory that contains the installer files. You can view the installer log file to get more information about the status of the upgrade and the tasks that are performed by the installer.

# Upgrading in Silent Mode

To upgrade a Data Vault component without user interaction, run the installer in silent mode.

Use a properties file to specify the upgrade options. The installer reads the properties file to determine the upgrade options. You can use silent mode to upgrade the Data Vault components on multiple machines on the network or to standardize the upgrade across machines. Set the values in the properties file and run the silent installer separately for each component that you want to upgrade.

To upgrade in silent mode, complete the following tasks:

1. Create the properties file and specify the upgrade options.
2. Run the installer with the properties file.

## Step 1. Create the Properties File

Informatica provides a sample properties file that includes the parameters that are required to upgrade a Data Vault component. You can customize the sample properties file to specify the options for your upgrade.

The sample properties file is named `SilentInput.properties` and is located in the root directory of the installation DVD or the installer download location. After you customize the file, save it back to the same file name `SilentInput.properties`.

The properties file contains all parameters required for installation and upgrade. You need to configure the parameters required for the upgrade. The installer ignores any parameter that is not used in the upgrade process.

1. Go to the root of the directory that contains the installer files.
2. Find the file named `SilentInput.properties`.  
Back up the file before you modify it.
3. Use a text editor to open the file and modify the values of the parameters.

The following table describes the upgrade parameters that you must set:

Property Name	Description
<code>INSTALL_TYPE_NEW</code>	Installs a Data Vault component. To upgrade a component, set this parameter to 0.
<code>INSTALL_TYPE_UPGRADE</code>	Upgrades a Data Vault component. Set this parameter to 1.
<code>USER_INSTALL_DIR</code>	Directory for the Data Vault component to upgrade. When you upgrade the Data Vault Data Archive plug-in, specify the directory that contains the instance of Data Archive where the plug-in is installed. When you upgrade other components, specify the directory that contains the Data Vault component that you want to upgrade.
<code>SILENT_INSTALL</code>	Installs in silent mode. Default is True. Do not change the default value.

4. Save the properties file with the name `SilentInput.properties`.

## Step 2. Run the Silent Installer

After you create the properties file, open a command window to start the silent installer. Use the same procedure to start a Data Vault component installation or upgrade.

1. Open a command window.
2. Go to the root of the directory where the installer files are located.
3. Verify that the directory contains the `SilentInput.properties` file that you modified.
4. Start the silent installer.  
On Windows, run the `silentinstall.cmd` file.  
On UNIX, run the `silentinstall.sh` file.

The silent installer runs in the background. The process can take a while.

The silent installer fails if you incorrectly configure the properties file or if the installation or upgrade directory is not accessible. If the installation or upgrade fails, view the log file named *FAS-installer.log* in the root of the directory that contains the installer files. Correct the problem and then run the silent installer again.

## Troubleshooting Data Vault Upgrade

### The upgrade fails with an "out of memory" error.

During the upgrade, the installer creates a backup of the entire Data Vault installation folder. If you have a huge metadata file or huge amount of log files, the upgrade might fail as the installer creates the backup folder.

To skip the backup folder creation, change directories to the installer location and on a command line, run the following command:

On Microsoft Windows:

```
install.cmd -DSKIP_BACKUP=true
```

On Linux or UNIX:

```
install.sh -DSKIP_BACKUP=true
```

To skip the backup creation of only the agent and server log folders, change directories to the installer location and on a command line, run the following command:

On Microsoft Windows:

```
install.cmd -DSKIP_LOG_BACKUP=true
```

On Linux or UNIX:

```
install.sh -DSKIP_LOG_BACKUP=true
```

If you skip the automatic backup creation, manually take a backup of the entire Data Vault installation folder.

## After You Upgrade

Complete the post-upgrade tasks before you use the new version of the Data Vault component.

1. View the installer log file to verify that the component was upgraded successfully.  
The installer creates the *FAS-installer.log* in the root of the directory that contains the installation files.
2. Verify the version of the upgraded component.  
You can view the version of each component separately, or you can view the versions of all components.

The following table describes how to verify the version for each Data Vault component:

Data Vault Component	How to Verify the Version
Data Vault server	From the root installation directory of the component, run the following command: <code>ssaserver --version</code>
Data Vault Agent	From the root installation directory of the component, run the following command: <code>ssaagent --version</code>
Data Vault ODBC driver	Locate the version in the .dll file properties. - 64-bit drivers on Windows: View the <code>install_dir/ODBC/sando.dll</code> and <code>install_dir/ODBC/sandos.dll</code> files. - 32-bit drivers on Windows: View the <code>install_dir/ODBC32/sando.dll</code> file.
Data Vault Plug-in	The Data Vault Plug-in is a package of multiple Data Vault components. To determine the version of each component, run the following commands: <code>ssaadmin --version</code> <code>ssau --version</code> <code>ssasql --version</code> <code>ssadriv --version</code> To determine the ODBC version, refer to the instructions in this table for the Data Vault ODBC driver.
Data Vault Administrator Tool and SQL Tool	From the root installation directory of the component, run the following command: <code>ssaadmin --version</code>

To view the versions of all Data Vault components, perform the following steps:

- From the root Data Vault installation directory, run the following command to connect to the Data Vault server:

```
ssaadmin dba
```

- Run the following `ssaadmin` command to view list of components and corresponding versions:

```
version
```

The `ssaadmin` command utility communicates with the server. The server gets the version for each component, even if the components are on separate machines.

- Start the Data Vault component.
- Verify that you can access the Data Vault from Data Archive.
- If you have a Data Vault in an external storage, verify that you can access the data in the external storage.
- Remove the following parameter from the META section of the `ssa.ini` file: `dvlp_MDConsistencyCheck = 0`

You might have added this parameter to the `ssa.ini` file in version 6.4 if the metadata consistency check was preventing the Data Vault server from starting. As of version 6.4 HF1, this parameter is no longer required.

# Reverting an Upgrade

At the start of the upgrade process, the installer creates a zip file of the upgrade directory. You can use the zip file to revert to the previous version of the Data Vault component.

1. Go to the root directory of the upgraded Data Vault component that you want to revert.
2. Find the zip file created by the installer.  
The zip file name starts with the Data Vault folder name and ends with a series of digits.
3. Copy the zip file to a backup directory.
4. Delete all files and directories in the root directory of the upgraded Data Vault component.
5. Extract all files from the zip file in the backup directory to the empty directory.

The extract process recreates the directory structure and copies all files to the appropriate directories. When the extract process completes, the directory contains the same directories and files as the previous version. You can use the Data Vault component as before.

On UNIX, the extract process does not reinstate the user account privileges to the directories and files. You must run the `chmod recursive` command to assign execute privileges to the Data Vault 6.4.0 files.

**Note:** You must revert all components to the same version. The Data Vault does not work with different versions of the components.

## CHAPTER 12

# ILM Data Validation Option Setup

This chapter includes the following topics:

- [ILM Data Validation Option Setup Overview, 96](#)
- [Before You Set Up the ILM Data Validation Option, 96](#)
- [Install the Data Vault Service ODBC Driver, 97](#)
- [Create a Data Vault Service ODBC Data Source, 99](#)
- [Create a PowerCenter Connection Object, 103](#)
- [After You Set Up the ILM Data Validation Option, 103](#)

## ILM Data Validation Option Setup Overview

If you have the ILM Data Validation option, you can use the Data Validation Option in PowerCenter to validate the data that you archive to the Data Vault.

You can use the Data Validation Option instead of running SQL queries or using other manual methods to validate archived data. Compare data in the source database with the data in the Data Vault to verify that data is archived correctly in the Data Vault.

The ILM Data Validation Option requires the following components:

- PowerCenter
- PowerCenter Data Validation Option
- Data Vault Service ODBC Driver

## Before You Set Up the ILM Data Validation Option

Before you set up the ILM Data Validation Option, verify that you have the required Informatica products installed.

Verify that you have the following Informatica products installed:

### **PowerCenter**

Install Informatica services and use the Administrator tool to create a PowerCenter Data Integration Service and a PowerCenter repository for use with the PowerCenter Data Validation Option.



For information about installing the Informatica services, see the *Informatica PowerCenter Installation and Configuration Guide*.

#### **PowerCenter Data Validation Option**

When you install the Data Validation Option, configure it to work with PowerCenter. The Data Validation Option includes a client application that you can use to perform data validation tasks.

For information about installing the PowerCenter Data Validation Option see the *Informatica PowerCenter Data Validation Option Installation and User Guide*.

## Install the Data Vault Service ODBC Driver

You must use the Data Vault Service ODBC driver to connect to the Data Vault.

Install the Data Vault Service ODBC driver on the machine that hosts the PowerCenter Integration Service.

### Installing the Data Vault ODBC Driver in Graphical Mode

You can install the Data Vault ODBC driver in graphical mode on Windows and UNIX. Install the ODBC driver on the machine that hosts the application you plan to use to access the Data Vault.

1. Log in to the machine with a system user account.
2. Close all other applications.
3. Begin the installation.
  - On Windows, run `install.cmd` from the root directory.

**Note:** On Windows 2012, right-click the command prompt icon and open the command prompt window using "Run As Administrator." Navigate to the installer location and run `install.cmd` from this command prompt window.
  - On UNIX, use a shell command line to run `install.sh` from the root directory.  
If you do not have an X Window server, the installer runs in console mode.
4. On the **Introduction** page, read the instructions and click **Next**.
5. On the **Installation Type** page, select **Install a Data Vault component** and click **Next**.
6. On the **License File** page, enter the path and file name of the Data Vault license key or click **Choose** to select a license key file.
7. On the **Components to Install** page, select **Data Vault ODBC Driver** and click **Next**.
8. On the **Installation Directory** page, enter the absolute path for the directory in which to install the Data Vault ODBC driver or click **Choose** to select or create a directory.

The path must conform to the length and character restrictions of the operating system.
9. Click **Next**.
10. On the **Pre-installation Summary** page, review the installation information, and click **Install** to continue.

The installer copies the Data Vault ODBC driver files to the installation directory. After the installation process completes, the **Installation Complete** page indicates whether the installation completed successfully.
11. Click **Done**.

The installer creates a log file named *FAS-installer.log* in the root of the directory that contains the installer files. You can view the installer log file to get more information about the tasks that are performed by the installer and to view configuration properties for the installed component.

## Installing the Data Vault ODBC Driver in Console Mode

You can install the Data Vault ODBC driver in console mode on UNIX. Install the ODBC driver on the machine that hosts the application you plan to use to access the Data Vault.

**Note:** On zLinux, you can install the Data Vault ODBC driver to query the Data Vault on Linux or Windows.

1. Log in to the machine with a system user account.
2. Close all other applications.
3. On a shell command line, run the `install.sh` file from the root of the directory where the installation files are located.

**Note:** If you are installing the Data Vault ODBC driver on a zLinux environment, you must unzip the installation file (`Informatica_Data_Vault_Native_Install_ODBC_zLinux_x64_6.4.3.zip`) and then navigate to the installer directory

(`Informatica_Data_Vault_Native_Install_ODBC_zLinux_x64_6.4.3`). To give the `install.bin` file permission to execute, run the following command: `chmod +x install.bin`

At the prompt, use the following syntax to install: `./install.bin`

The **Introduction** section appears.

4. Press ENTER to continue.

The **Installation Type** section appears.

5. Press 1 to install a Data Vault component and press ENTER.

The **License File** section appears.

6. Type the full path and file name of the Data Vault license key and press ENTER.

The **Select a Component to Install** section appears.

7. Press 3 to install the Data Vault ODBC driver and press ENTER.

The **Specify the Installation Directory** section appears.

8. Type the path for the directory in which to install the Data Vault ODBC driver or press ENTER to use the default directory.

9. Verify that the installation directory is correct and press Y to continue.

The **Pre-Installation Summary** section appears.

10. Review the installation information, and press ENTER to continue.

The installer copies the files to the installation directory. After the installation process completes, the installer indicates whether the installation completed successfully.

11. Press ENTER to exit the installer.

The installer creates a log file named *FAS-installer.log* in the root of the directory that contains the installer files. You can view the installer log file to get more information about the tasks that are performed by the installer and to view configuration properties for the installed component.

# Create a Data Vault Service ODBC Data Source

Create an ODBC data source that uses the Data Vault Service ODBC driver to connect to the Data Vault.

## Creating an ODBC Data Source on Windows

You can use the Windows ODBC Data Source Administrator to create the ODBC data source. When you create the data source, the Windows ODBC Data Source Administrator stores the ODBC driver parameters in the Windows registry.

### Using the Windows ODBC Data Source Administrator to Create a Data Source

Windows provides an administrative tool to create and manage ODBC data sources.

1. From the Start Menu, select **Administrative Tools > Data Sources (ODBC)**.
2. In the ODBC Data Source Administrator, add a DSN.
3. Select the following driver: **Nucleus ODBC Driver**
4. Set the parameters for the Data Vault ODBC driver.

### Data Vault ODBC Data Source Parameters

When you create an ODBC data source that uses the Data Vault ODBC driver, you must configure the parameters required for the Data Vault ODBC driver.

The following table describes the parameters that you set for a data source that uses the Data Vault ODBC driver:

ODBC Parameter	Description
Data Source Name	Name of the ODBC data source.
Description	Additional information to describe the data source.
Database name	Name of the folder in the Data Vault to connect to.
Database user	User account to log in to the Data Vault. The user account must be defined in Data Archive.
Connection name	Name of a Data Archive connection to the Data Vault. The connection name must match a target connection defined in the Data Archive Workbench.
Host	Host name of the machine that hosts the Data Vault Service.
Port	Port number to connect to the Data Vault.

The following table describes the advanced parameters that you can set for a data source that uses the Data Vault ODBC driver:

ODBC Parameter	Description
Code page	The code page to use for code page translations between the client and the Data Vault. Select from one of the following options: <ul style="list-style-type: none"> <li>- 1252 (ANSI - Latin I)</li> <li>- 65001 (UTF-8)</li> </ul>
Date, Time, Number formats	Format to use for date, time, and numeric values. Select from one of the following options: <ul style="list-style-type: none"> <li>- ISO</li> <li>- Regional settings</li> </ul>
Autorefresh	Configures the Data Vault ODBC driver to commit or roll back all transactions before each SELECT statement so that the client accesses the most recent version of the Data Vault archive folder. Select the Autorefresh parameter and then set the parameter to one of the following options: <ul style="list-style-type: none"> <li>- Commit. The ODBC driver commits all transactions before the next query.</li> <li>- Rollback. The ODBC driver rolls back all transactions before the next query.</li> </ul> By default, the Autorefresh parameter is not enabled and the ODBC driver does not commit or roll back transactions before a SELECT statement.
Autocommit	Configures the Data Vault ODBC Driver to commit transactions after each SQL command that modifies data such as an UPDATE or INSERT. Select the parameter to enable the ODBC driver to commit transactions after each SQL command that modifies data. By default, the Autocommit parameter is not enabled and ODBC Driver does not commit transactions after each SQL command that modifies data.

## Creating an ODBC Data Source on UNIX

On UNIX, you can use any ODBC driver manager such as iODBC or unixODBC to create an ODBC data source. The ODBC driver manager adds an entry for the ODBC data source definition to the `odbc.ini` file.

You can also manually add the ODBC data source definition to the `odbc.ini` file. On UNIX, all ODBC data source definitions are stored in the `odbc.ini` file. You can add or modify an ODBC data source definition in the `odbc.ini` file without using the ODBC driver manager interface.

Typically, the `odbc.ini` file is located in the user `/etc` directory. For example, for unixODBC, the `odbc.ini` file is in the following directory:

```
/usr/local/etc
```

To verify the location of the `odbc.ini` file, check the `ODBCINI` environment variable.

## Data Vault ODBC Driver

Use the correct Data Vault ODBC driver for the 32-bit or 64-bit operating system. The 32-bit and 64 bit ODBC driver files have the different names and are installed in the same directory.

The following table describes the Data Vault ODBC driver files on UNIX:

Operating System	ODBC Driver
32-bit operating system	<Data Vault ODBC Driver Directory>/odbc32/libsando.so
64-bit operating system	<Data Vault ODBC Driver Directory>/odbc/libsando64.so

## Data Vault ODBC Data Source Parameters

When you create an ODBC data source that uses the Data Vault ODBC driver, you must configure the parameters required for the Data Vault ODBC driver.

The following table describes the parameters that you set for a data source that uses the Data Vault ODBC driver:

ODBC Parameter	Description
Data Source Name	Name of the ODBC data source.
Description	Additional information to describe the data source.
Database name	Name of the folder in the Data Vault to connect to.
Database user	User account to log in to the Data Vault. The user account must be defined in Data Archive.
Connection name	Name of a Data Archive connection to the Data Vault. The connection name must match a target connection defined in the Data Archive Workbench.
Host	Host name of the machine that hosts the Data Vault Service.
Port	Port number to connect to the Data Vault.

The following table describes the advanced parameters that you can set for a data source that uses the Data Vault ODBC driver:

ODBC Parameter	Description
Code page	The code page to use for code page translations between the client and the Data Vault. Select from one of the following options: <ul style="list-style-type: none"><li>- 1252 (ANSI - Latin I)</li><li>- 65001 (UTF-8)</li></ul>
Date, Time, Number formats	Format to use for date, time, and numeric values. Select from one of the following options: <ul style="list-style-type: none"><li>- ISO</li><li>- Regional settings</li></ul>

ODBC Parameter	Description
Autorefresh	<p>Configures the Data Vault ODBC driver to commit or roll back all transactions before each SELECT statement so that the client accesses the most recent version of the Data Vault archive folder.</p> <p>Select the Autorefresh parameter and then set the parameter to one of the following options:</p> <ul style="list-style-type: none"> <li>- Commit. The ODBC driver commits all transactions before the next query.</li> <li>- Rollback. The ODBC driver rolls back all transactions before the next query.</li> </ul> <p>By default, the Autorefresh parameter is not enabled and the ODBC driver does not commit or roll back transactions before a SELECT statement.</p>
Autocommit	<p>Configures the Data Vault ODBC Driver to commit transactions after each SQL command that modifies data such as an UPDATE or INSERT. Select the parameter to enable the ODBC driver to commit transactions after each SQL command that modifies data.</p> <p>By default, the Autocommit parameter is not enabled and ODBC Driver does not commit transactions after each SQL command that modifies data.</p>

## odbc.ini File

On UNIX, the Data Vault ODBC driver uses the information in the odbc.ini file to determine how to connect from an ODBC client to the Data Vault.

The odbc.ini file must include a section for each ODBC data source definition. The section starts with a header that specifies the name of the DSN. The section includes the ODBC parameters defined for the data source.

The following ODBC entry for the *OptFileArchive* data source shows an example of a DSN that uses the Data Vault ODBC driver:

```
[OptFileArchive]
DRIVER=/usr/FAS/libsando.so
DATABASE=FASfolder100
CONNECTION=server1_dbtest
HOST=myhost
PORT=8600
UTF8Data=1
UseRegionalSettings=1
AUTOREFRESH=1
AUTOCOMMIT=0
```

## ODBCINI Environment Variable

The ODBCINI environment variable stores the location of the ODBC.ini file.

You can view or set the value of the ODBCINI variable in the initialization file for the UNIX shell that you use. For example, on the Korn or Bourne shell, you can set the ODBCINI variable in the .profile file. On the C shell, you can set the variable in the .cshrc file.

To set the ODBCINI variable, add the following command to the shell initialization file:

### .profile

```
ODBCINI=/<Path and file name of the odbc.ini file>
export ODBCINI
```

### .cshrc

```
setenv ODBCINI /<Path and file name of the odbc.ini file>
```

## Create a PowerCenter Connection Object

Use a PowerCenter connection to connect to the Data Vault.

In the PowerCenter Workflow Manager, create a connection object that uses a Data Vault Service ODBC data source to connect to the Data Vault archive folder that you want to validate.

For information about creating connection objects for PowerCenter, see the *Informatica PowerCenter Workflow Basics Guide*.

## After You Set Up the ILM Data Validation Option

After you complete the Data Validation option setup, you can use the Data Validation Option Client to validate the data that you archive to the Data Vault.

For information about using the PowerCenter Data Validation Option, see the *Informatica PowerCenter Data Validation Option Installation and User Guide*.

## CHAPTER 13

# Data Archive Source and Target Database Requirements

This chapter includes the following topics:

- [Source Database Requirements, 104](#)
- [Target Database Requirements, 106](#)

## Source Database Requirements

Verify the source database requirements. The source database is the location where you archive data from and is typically referred to as the production database. You can verify the requirements before or after the installation.

You can archive data from the following source database types:

- IBM DB2
- Informix
- JDBC
- Microsoft SQL Server
- MongoDB
- Netezza
- Oracle
- Sybase ASE
- Teradata
- Salesforce

For other databases, for example MySQL, use a generic JDBC driver to connect to the source database as a generic JDBC source connection.

You may need to create a staging tablespace or have additional staging space available on the source database. The staging tablespace creates space for the data only and not the index.

Data Archive requires a staging tablespace in the following cases:

- Live archiving jobs.
- Archive jobs that use Oracle partition exchange to purge data from the source database.



Data Archive requires staging space for retirement jobs that retire SAP applications with attachments.

## Live Archiving

Create a data staging tablespace in the source database for all live archive jobs. For example, AM\_STAGING\_D.

All live archive jobs require staging space. The archive job uses the staging space to store the following tables:

### Interim tables

The archive job creates interim tables for business rule validation and candidate generation during the archive process.

The staging space requirements depend on the size of the interim tables. Configure the tablespace size to the number of archived rows from the largest table in a single archive job multiplied by the average row size. A general guideline is to use 1K for the average row size.

### Staging tables

If you enable staging for the archive source connection, the archive job creates staging tables. The staging tables temporarily store a copy of the archived data before the archive job moves the data to the archive or history database.

The staging space requirements depend on the size of the data in the archive job. Configure the tablespace size to the largest amount of archived data in a single archive job.

Staging space is not required for retirement jobs. Retirement jobs do not validate business rules, generate candidates, or create staging tables because the jobs archive all source data.

## Oracle Partition Exchange Purging

Verify that the staging tablespace includes space for archive jobs that use Oracle partition exchange to purge data from the source database. The amount of staging space depends on the amount of data that is going to be kept in the source table.

When the archive job runs the partition exchange procedure, the procedure only creates one keep table. When the database completes the partition exchange for the source table, the procedure drops the keep table. This process is repeated for every table that is configured for partition exchange. The size of the keep table depends on each source table. Verify that you have enough staging space for the maximum difference between the source and staging tables.

To estimate the amount of required staging space, configure the archive job to pause after the copy to staging step. Review the log to calculate the sizes of the staging tables and the source tables.

## SAP Application Retirement

Verify that you have staging space for retirement jobs that archive SAP applications. File system staging space is required to archive attachments.

To retire attachments from SAP applications, you must have staging space in a file system that is accessible to the SAP system. The staging space requirements depend on the amount and size of the BCP files and attachments you plan to retire in the retirement project.

Verify that the staging space is at least four times larger than the size of the data that you plan to retire in a single retirement project.

By default, the retirement job saves the BCP files that it creates for the cluster and pool tables, to the staging space. The retirement job also downloads all attachments that are stored in the SAP database and in a file system to the staging space. For attachments that are stored in the SAP database, the job compresses and downloads the attachments to this staging space. For attachments that are stored in a file system, the job moves the attachments to the staging space.

You can leave the BCP files and attachments in the staging space. Or, you can move the BCP files attachments from the staging space to another file system, external storage, or the Data Vault. Optionally, you can configure the attachment entities to keep the attachments in the file system if you do not want to move attachments from the original file system to the staging space.

## Target Database Requirements

Verify the target database requirements when you archive to another database. The target database is the location where you archive data to and is typically referred to as the history or archive database. You can verify the requirements before or after the installation.

The target database must be on the same platform and version as the source database. For example, if you archive from an Oracle 10g database, the target database must be Oracle 10g.

Create the following history tablespaces when you archive to another database:

- History data tablespace. For example, AM\_HISTORY\_D. The history data tablespace stores the archived data.
- History index tablespace. For example, AM\_HISTORY\_X. The history index tablespace stores the associated indexes of the archived data.

The history tablespace requirements depend on the size of the data and indexes in the archive job. Configure the tablespace size to at least the same size of the source instance to store all data and the associated indexes to be archived.

# CHAPTER 14

## Data Archive Connectivity

This chapter includes the following topics:

- [Data Archive Connectivity Overview, 107](#)
- [Native Connectivity, 107](#)
- [DataDirect Connect JDBC Connectivity, 108](#)
- [PowerExchange Connectivity, 108](#)
- [Third-Party JDBC Connectivity, 109](#)

### Data Archive Connectivity Overview

Data Archive uses different types of connectivity to communicate with source and target databases.

#### **Native connectivity**

The ILM Engine connects to the data source using a vendor-provided JDBC driver or other vendor proprietary connectivity.

#### **DataDirect Connect JDBC connectivity**

The ILM Engine connects to the data source using DataDirect JDBC drivers provided by Informatica. DataDirect JDBC drivers are packaged with Data Archive and are the preferred method of connecting to data sources for which Data Archive does not provide native connectivity.

#### **PowerExchange connectivity**

The ILM Engine connects to a mainframe data source through the PowerExchange ODBC drivers that are included with PowerExchange.

#### **Third-party JDBC connectivity**

Data Archive supports connectivity to any JDBC data source. If Informatica does not provide an adapter for your desired data source, you may be able to get a third-party JDBC adapter.

### Native Connectivity

You can configure Data Archive to use database native utilities for data movement.

Native utilities are the preferred method of connectivity because the ILM Engine can leverage database-specific SQL or vendor-specific operations to improve the performance of retrieving and inserting data.

Native connectivity also enables seamless access from the original application interface.

You can use native connectivity with the following types of databases:

- Oracle
- Microsoft SQL Server
- IBM DB2
- Teradata
- Netezza

You can also use the Teradata Parallel Transporter to export data from Teradata sources on Linux to the Data Vault.

You can configure Netezza databases to use the nzLoad utility for bulk data movement.

## DataDirect Connect JDBC Connectivity

You can configure Data Archive to use DataDirect Connect JDBC drivers to connect to data sources.

Data Archive uses JDBC drivers to connect to source, target, and lookup databases. DataDirect Connect JDBC drivers are packaged with Data Archive and are the preferred method of connectivity if native connectivity is not supported.

You can use DataDirect Connect JDBC connectivity with the following types of databases:

- IBM DB2 LUW
- IBM DB2 for i, i5/OS or AS/400
- IBM DB2 for z or z/OS
- Informix
- Sybase ASE

## PowerExchange Connectivity

Data Archive can use PowerExchange ODBC drivers to access nonrelational data on z/OS.

Data Archive uses a JDBC-ODBC bridge to connect to the z/OS source data through the ODBC drivers that are included with PowerExchange.

You must install the UNIX ODBC package if your PowerExchange adapter is on one of the following operating systems:

- UX
- Linux

For information on installing the UNIX ODBC package, go to: <http://www.unixodbc.org/>

After you install the UNIX ODBC package, set the environmental variable `LD_PRELOAD` with the file path of the `libodbc.so` file. For example:

```
export LD_PRELOAD=/usr/lib64/libodbc.so
```

You can retire the following types of nonrelational z/OS data:

- Adabas
- C-ISAM
- Datacom
- IDMS
- IMS
- VSAM
- Sequential data sets

## Third-Party JDBC Connectivity

You can configure Data Archive to use third-party JDBC adapters to connect to data sources.

Data Archive supports connectivity to any JDBC data source through third-party adapters.

## CHAPTER 15

# Data Archive Uninstallation

This chapter includes the following topics:

- [Data Archive Uninstallation Overview, 110](#)
- [Restore Archived Data, 110](#)
- [Dropping Database Users and Links, 111](#)
- [Dropping the ILM Repository, 111](#)
- [Deleting the ILM Application Server Directory, 111](#)
- [Uninstalling the Data Vault, 111](#)
- [Uninstalling Source Adapters, 112](#)
- [Deleting Remaining ILM Files, 112](#)

## Data Archive Uninstallation Overview

To uninstall Data Archive, you must drop all of the database users and links that you created for archiving. You can then drop the ILM repository and delete the ILM server directory.

If you use the Data Vault Service, you must uninstall it separately and remove the associated ODBC/JDBC drivers.

To uninstall Data Archive, perform the following tasks:

1. Complete prerequisite steps.
2. Drop all database users and links.
3. Drop the ILM repository.
4. Delete the ILM server directory.
5. Uninstall the Data Vault Service.
6. Uninstall any source adapters.
7. Delete any remaining ILM files.

## Restore Archived Data

Before you uninstall Data Archive, log in to the web application. If you want to retain archived data, restore it from the history database or Data Vault before you drop any database links or users.

# Dropping Database Users and Links

You must drop the database users and links for each source connection created for archiving.

1. Click **Administration > Manage Connections**.
2. Click on a connection name to find the attributes for the database link.
3. Drop the database link from that connection.
4. Find the attribute for the staging user.
5. Drop the staging user and tablespace.
6. Drop the seamless access layer:
  - a. Delete the seamless access application layer.
  - b. Drop the seamless access users from the source.
  - c. Drop the database link that is associated for seamless access.
7. For target connections, drop the history user and tablespace.

# Dropping the ILM Repository

1. Drop the ILM repository user.
2. Drop the data tablespace for the ILM repository user.
3. Drop the index tablespace for the ILM repository user.

# Deleting the ILM Application Server Directory

Navigate to the ILM application server directory and delete the directory.

# Uninstalling the Data Vault

When you uninstall the Data Vault, you uninstall all of the Data Vault components.

Before you uninstall the Data Vault, verify that the Data Vault Service is not running.

To uninstall the Data Vault on Windows, run `Uninstall_ILM-FAS.exe` from the Data Vault root directory.

To uninstall the Data Vault on UNIX, delete the Data Vault component directory.

**Note:** Uninstall the Data Vault Data Archive plug-in when you uninstall Data Archive. Do not uninstall the Data Vault Data Archive plug-in separately. If you uninstall the plug-in only, Data Archive can fail.

## Uninstalling Source Adapters

If you use source adapters, such as IBM DB2 or IBI iWay legacy adapters, follow the uninstallation steps for the adapters.

## Deleting Remaining ILM Files

Delete any remaining ILM files, such as installation or documentation files.



## CHAPTER 16

# SAP Application Retirement

This chapter includes the following topics:

- [SAP Application Retirement Overview, 113](#)
- [SAP Application Retirement Architecture Options, 113](#)
- [Setting Up SAP Application Retirement, 115](#)
- [Step 1. Install the SAP Java Connector, 116](#)
- [Step 2. Apply the SAP Transports, 116](#)
- [Step 3. Assign Roles, 117](#)
- [Step 4. Configure Conf.Properties, 117](#)
- [Step 5: Set up the FTP or NFS Connection, 117](#)

## SAP Application Retirement Overview

You can use Data Archive to retire SAP applications to the Data Vault. When you retire an SAP application, Data Archive retires all standard and custom tables in all of the installed languages and SAP clients. Data Archive also retires all attachments that are stored within the SAP database and in an external file system or storage system.

In SAP applications, you can use the Archive Development Kit (ADK) to archive data. When you archive within SAP, the system creates ADK files and stores the files in an external file system. When you retire an SAP application, you also retire data stored in ADK files.

After you retire the application, you can use the Data Validation Option to validate the retired data. You can use the Data Discovery portal or other third-party query tools to access the retired data.

## SAP Application Retirement Architecture Options

The SAP application server cannot write data from attachments or special tables such as cluster and pool tables, directly to an external drive. For this reason, you must provide a connection between the SAP application server and the Data Archive staging area.

You can connect the SAP application server and the Data Archive staging area in one of the following ways:

- Use FTP

- Use NFS

Informatica recommends the FTP option.

### FTP Option

To use the FTP option, install the FTP server on the same location as the Data Archive staging area. Specify the SAPFTP properties. Provide the FTP connection details such as location and log-in credentials when you configure the source connection.

When you retire an SAP application, Data Archive first moves the attachments and the data from the special tables to the file system on the SAP application server. Then, Data Archive pushes the files to the FTP folder in the staging area.

The following image shows the SAP application retirement architecture with the FTP option:

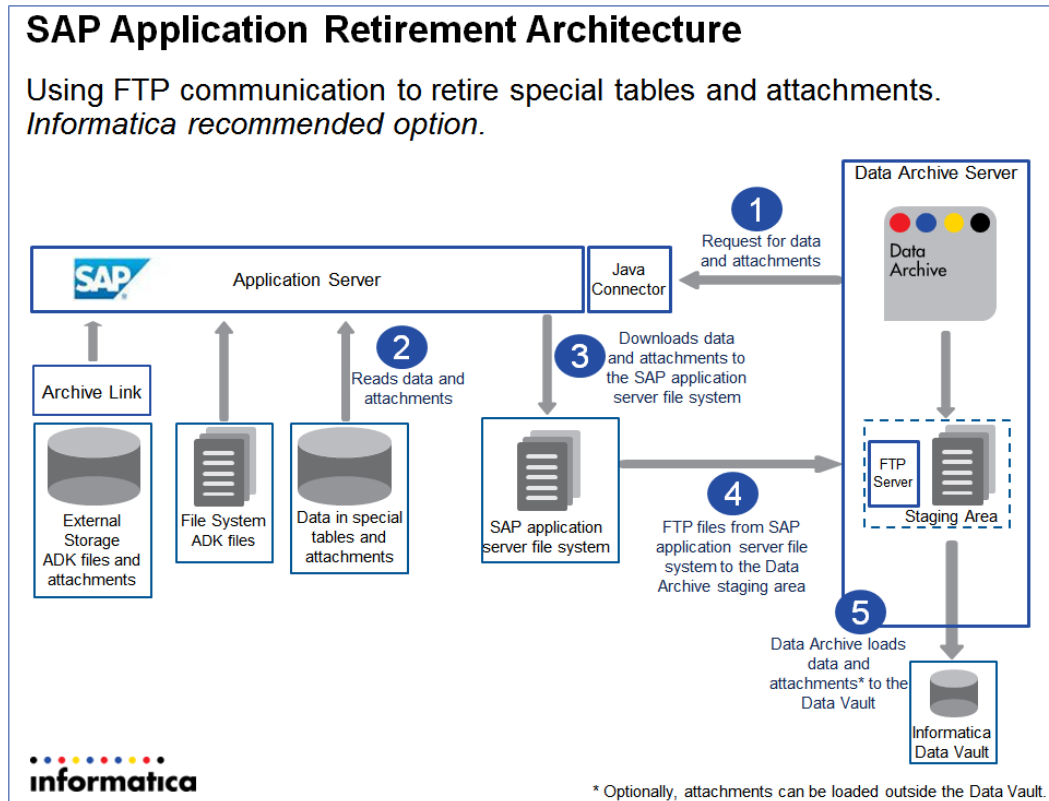

### NFS Option

To use the NFS option, create a mount point on the file system of the SAP application server. Specify the mount point location when you configure the source and target connections.

When you retire an SAP application, Data Archive loads the attachments and the data from the special tables to the Data Archive staging area through the shared file system.

The following image shows the SAP application retirement architecture with the FTP option:

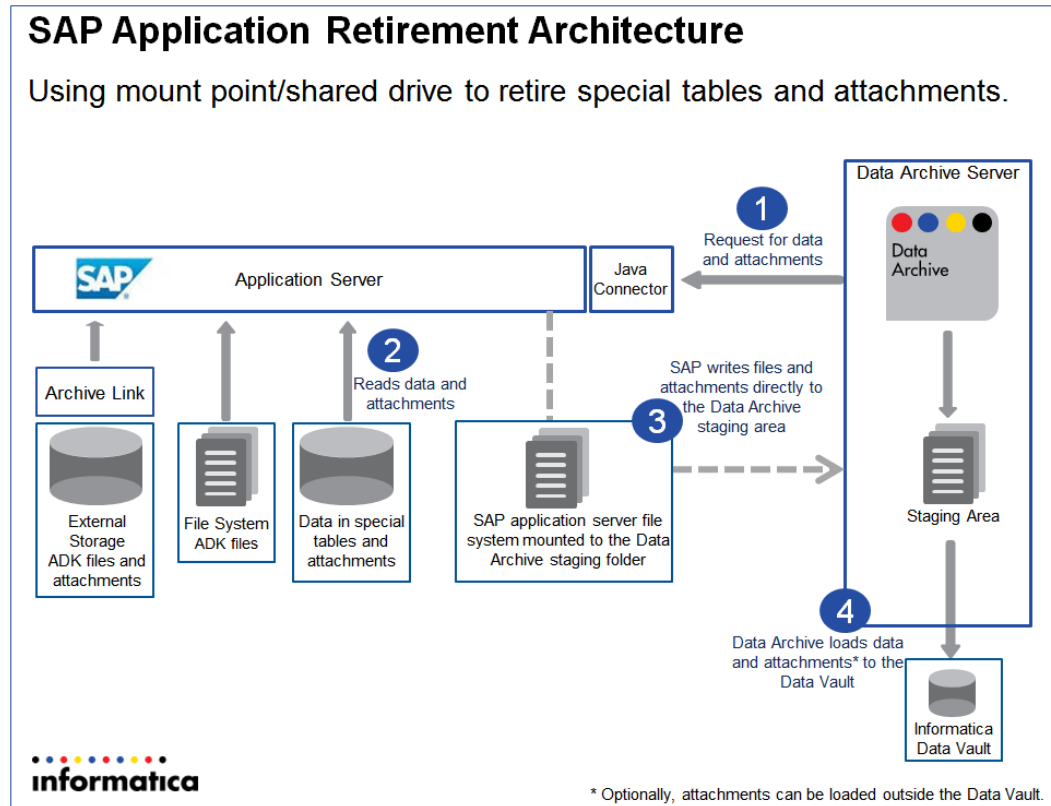

## Setting Up SAP Application Retirement

You can configure Data Archive to retire data from SAP applications.

Before you begin, verify the following prerequisites:

- You have the required authorizations.
- The size of the staging folder on the SAP application server is at least four times the size of the data that you plan to retire in a single retirement project.
- If you are upgrading from a previous version of the SAP accelerator, delete the "SAP" folder in both the Data Archive Installation directory and in the application (Visualization > Reports and Dashboards) before you upgrade the accelerator. Also delete INFA\_REPORTS from the Data Archive installation directory.

Complete the following tasks to setup SAP application retirement:

1. Install the SAP Java Connector.
2. Apply the SAP transports.
3. Assign roles.
4. Configure the `conf.properties` file.
5. Set up the FTP or NFS connection.

## Step 1. Install the SAP Java Connector

Download the SAP Java Connector, version 3.0.12 or later, from the SAP Marketplace and install the SAP Java Connector on the machine that hosts Data Archive. The retirement job uses the SAP Java Connector to log in to the SAP application to read data from special tables, ADK files, and attachments.

1. Use the following URL to access the SAP Marketplace:

<http://service.sap.com/connectors>

**Note:** SAP requires authentication to the SAP Marketplace. If you do not have the credentials to access SAP Marketplace, contact Informatica Global Customer Service and create a ticket for further guidance. Provide the following information about the server on which Data Archive is installed:

- Operating system
- 32- or 64-bit architecture

2. Navigate to the SAP Java Connector download page.

3. Download version 3.0.12 or later. Choose the file for the platform that hosts Data Archive.

For example, the SAP system is on Windows and Data Archive is on Linux. Choose the Linux version.

4. Install the SAP Java Connector on the machine that hosts Data Archive.

The installation instructions depend on the operating system. Follow the instructions provided by SAP for the operating system of the machine that hosts Data Archive.

**Tip:** You can find the installation instructions after you unzip the downloaded file. The `Readme.txt` files provide instructions on how to access the documentation. Review the `Readme.txt` files in the following directories:

```
<SAP Java Connector>
<SAP Java Connector>/docs/jco
```

5. After you install the SAP Java Connector, copy the `sapjaco.jar` file from the root directory of the SAP Java Connector installation and paste to the following location:

```
<Data Archive installation>/webapp/WEB-INF/lib
```

6. Restart the ILM application server.

## Step 2. Apply the SAP Transports

To retire SAP applications, you must install SAP transports to the SAP application that you want to retire. After you install the SAP Retirement Accelerator, the transport files are available in the Data Archive installation directory.

The transports include a role and remote function calls (RFCs) to allow Data Archive to run the retirement job on the SAP database. The transports create objects in the ZINFA\_RETIREMENT package. The transports do not modify any standard SAP objects.

You can access the transports in the following Data Archive directory:

```
<Data Archive Installation>\optional\SAP_retirement_transports.zip
```

The transports you install depend on the SAP module and version. The zip file includes a readme file that lists the required transports for each SAP module and version.

Import the transports as client-dependent. Import the transports in the client that contains the SAP system user with RFC connection authorizations.

## Step 3. Assign Roles

Assign the user that runs the retirement job to a retirement-specific role. You provide the user in the source connection.

The ZINFA\_RETIREMENT\_PREPARATION role is included in the SAP transports. After you apply the SAP transports, assign the role to the user that will run the retirement project. Assign to any user that has remote function call (RFC) connection authorization. The role includes authorization to call remote function modules to access data from the SAP data dictionary.

## Step 4. Configure Conf.Properties

Change the BCP file delimiters in the `conf.properties` file to unique values that are not included in the SAP table data. If you use values that are included in the SAP table data, then the retirement job generates BCP files that are not valid. You can find the `conf.properties` file in the root Data Archive installation directory.

The following table contains examples of the properties and the values to configure:

Property	Value
<code>informia.bcp.columnSeparator</code>	<code>^^</code>
<code>informia.bcp.rowSeparator</code>	<code>@#@#</code>

**Note:** If the SAP application is installed on a Microsoft SQL Server database, you must also enable the following property in the `conf.properties` file by setting the value to "Y":

```
informia.sqlServerVarBinaryAsVarchar=Y
```

## Step 5: Set up the FTP or NFS Connection

SAP can write data from special files and attachments only to the SAP application server. To facilitate SAP application retirement, you must create a connection between the SAP application server and the Data Archive staging area.

Use one of the following options to create the connection between the SAP application server and the Data Archive staging folder:

- FTP
- NFS Mount

### Creating the FTP Connection

Install the FTP server and user. Specify the connection properties in the source and target connections.

To create the FTP connection, perform the following high-level steps:

1. Install the FTP server in the same location as the Data Archive staging folder.
2. Create the FTP user.

3. Assign the FTP user with read, write, append, and delete permissions to the FTP folder.
4. Create and maintain an entry in the SAPFTP\_SERVERS table.  
For instructions on configuring SAPFTP and the list of SAP supported versions, see *SAP Note 1605054*.
5. Set the FTP property **Connection Timeout** to a value between 1,200 and 2,000 seconds.
6. Configure the Data Archive source connection.

Specify the required source connection properties. In addition, specify the properties specific to SAP application retirement.

The following table lists the required properties for SAP application retirement with the FTP option:

Property	Description
Source/Staging Attachment Location	The directory path of the staging folder on the SAP application server. SAP downloads the attachments and saves the BCP files to this folder. Enter the full path of the location. For example: \\10.1.10.10\interfaces\CCO\ Depending on the OS, the path must end with "/" or "\".
SAP Fetch Size	Number of rows that the retirement job extracts at a time from the SAP cluster and pool tables to write to the BCP file.
SAP Host	Host of the SAP application that you want to retire.
SAP Client	Client in which the user logs in. Note that all clients in the SAP application are retired.
SAP System Number	System number in which the user logs in.
SAP Language	Language in which the user logs in. Note that all languages in the SAP application are retired.
SAP User	User that logs in to the SAP application. The user must be assigned to the ZINFA_RETIREMENT_PREPARATION role and include RFC connection authorizations.
SAP User Password	Password for the SAP user.
FTP User	User name to connect to the FTP server.
FTP Password	Password for the FTP user.
FTP Host	Host name of the FTP server.
FTP Port	Port number of the FTP server. Default port is 21.
FTP Folder Location	Name of the FTP folder on the Data Archive server. For example, ERP\ Depending on the OS, the folder name must end with "/" or "\".

7. If you want Data Archive to save the BCP files in compressed file format, enable the check box for the **Compressed** property in the source connection.  
If enabled, Data Archive compresses BCP files and saves them as .gz files in the Data Archive staging folder. If not enabled, Data Archive saves BCP files as .bcp files.
8. Configure the Data Vault target connection.

For the **Staging Directory** property, enter the full directory path of the FTP folder on the Data Archive server. For example, C:\user\FTP\ERP\.

9. Create the SAP application retirement project.

For more information, see the chapter "SAP Application Retirement" in the *Informatica Data Archive User Guide*.

## Creating the NFS Mount

Use an NFS mount to create a shared file system between the SAP application folder and the Data Archive staging folder. Specify the connection properties in the source and target connections.

To create the NFS mount, perform the following high-level steps:

1. In the SAP application server file system, set up an NFS mount point to the Data Archive staging folder.
2. Set up the user with access to the Data Archive staging folder. If the SAP system is on Windows, that user must have the standard read, write, append, and delete permissions to this folder.
3. Configure the Data Archive source connection.

Specify the required source connection properties. In addition, specify the properties specific to SAP application retirement.

The following table lists the required properties for SAP application retirement with the FTP option:

Property	Description
Source/Staging Attachment Location	The directory path of the staging folder on the SAP application server. SAP downloads the attachments and saves the BCP files to this folder. Enter the full path of the location. For example, \ \10.1.10.10\interfaces\CCO\ <b>Note:</b> You must specify the same directory path for the <b>Staging Directory</b> target connection property.
SAP Fetch Size	Number of rows that the retirement job extracts at a time from the SAP cluster and pool tables to write to the BCP file.
SAP Host	Host of the SAP application that you want to retire.
SAP Client	Client in which the user logs in. Note that all clients in the SAP application are retired.
SAP System Number	System number in which the user logs in.
SAP Language	Language in which the user logs in. Note that all languages in the SAP application are retired.
SAP User	User that logs in to the SAP application. The user must be assigned to the ZINFA_RETIREMENT_PREPARATION role and include RFC connection authorizations.
SAP User Password	Password for the SAP user.

4. If you want Data Archive to save the BCP files in compressed file format, enable the check box for the **Compressed** property in the source connection.

If enabled, Data Archive compresses BCP files and saves them as `.gz` files in the Data Archive staging folder. If not enabled, Data Archive saves BCP files as `.bcp` files.

5. Configure the Data Vault target connection.

For the **Staging Directory** property, enter the same directory path that you entered for the **Source/ Staging Attachment Location** source connection property.

6. Create the SAP application retirement project.

For more information, see the chapter "SAP Application Retirement" in the *Informatica Data Archive User Guide*.



# APPENDIX A

## Database Users and Privileges

This appendix includes the following topics:

- [Database Users and Privileges Overview, 121](#)
- [Administration User, 121](#)
- [Production Application User, 123](#)
- [Staging User, 123](#)
- [History Read-Only User, 125](#)
- [History Application User, 125](#)
- [Combined User and Archive User for Seamless Access, 126](#)
- [IBM DB2 Privileges, 127](#)
- [SAP Application Retirement Privileges, 129](#)

### Database Users and Privileges Overview

After you install Data Archive, set up the required database users and configure additional privileges.

Data Archive uses different database users during the archive process. Before you run an archive or retirement project, set up the required database users. Verify that the users have the correct authorizations.

You may need to configure additional privileges depending on the source database or the source application that you want to archive data from. Set up additional privileges to archive from IBM DB2 sources or to retire SAP applications.

### Administration User

The administration database user has DBA rights to the database, including the ability to run DDL and access system-level objects.

The administration user typically resides on both the source and target databases. During the archive process, the administration user queries the catalog tables. You can use the administration user to create and drop the public database link if the database link to the repository does not exist.

The administration user requires the following user privileges for the installation:

Oracle Privileges	Microsoft SQL Server Privileges	IBM Db2 Privileges
ALTER SESSION	ALTER EVENT SESSION	ALTER SESSION
ALTER USER	ALTER USER	
CREATE SESSION	CREATE EVENT SESSION	CREATE EVENT SESSION
CREATE USER	CREATE USER	
CREATE TABLESPACE	Not applicable	
GRANT CONNECT	GRANT CONNECT/CREATE USER	
SELECT_CATALOG_ROLE	SELECT	
Grant any privilege TO <i>user_name</i> with admin option.	Grant any privilege TO <i>user_name</i> with admin option.	Grant any privilege TO <i>user_name</i> with admin option.

The administration user typically requires the following user privileges for archive processes:

- SELECT DBA\_SEGMENTS. Required for the generate candidates row count report.
- SELECT ANY TABLE. Not required if the administration user has access to application user tables.
- CREATE PUBLIC DATABASE LINK. Not required if the archive connection definition includes the database link name.
- DROP PUBLIC DATABASE LINK. Not required if the archive connection definition includes the database link name.

The administration user requires select privileges on the following views in order for the DGA Data Collection job to run successfully:

- DBA\_DATA\_FILES
- DBA\_FREE\_SPACE
- DBA\_INDEXES
- DBA\_SEGMENTS
- DBA\_TABLES
- DBA\_TABLESPACES

### Microsoft SQL Server Requirements

On Microsoft SQL Server, the Administration user must have the serveradmin role.

# Production Application User

The production application user resides on the source database and is either the owner of the tables that you want to archive or partition, or the user that has full rights to the tables that you want to archive or partition. During the archive process, you can use the production application user to delete from the source. Alternatively, you can configure the source connection to use the staging user to delete data from the source.

The production application user typically requires the following user privileges:

- Select, insert, update, and delete privileges on all application tables.
- CREATE ANY TRIGGER and ALTER ANY TRIGGER. Required if triggers on application tables are owned by a different user.
- SELECT ANY TABLE. Required to access the staging tables only if you use the production application user for the delete from source step.
- Read-only access to the directory that contains binary files if the source data contains BFILE datatypes.

# Staging User

The staging database user stores interim tables for business rule validation and generates candidates during the archive and partitioning processes. If you enable staging for the archive source connection, the staging user also creates staging tables. The staging tables temporarily store a copy of the archived data before the archive job moves the data to the archive or history database. The staging user typically resides in the source database.

## Required Privileges

The following table lists the privileges required for the staging database user:

Oracle Privileges	Microsoft SQL Server Privileges	IBM DB2 Privileges
ALTER SESSION	ALTER EVENT SESSION	ALTER SESSION
CONNECT	For information about creating connections to the SQL Server database, see <a href="http://msdn.microsoft.com/en-us/library/s4yys16a(v=vs.90).aspx">http://msdn.microsoft.com/en-us/library/s4yys16a(v=vs.90).aspx</a>	CONNECT
CREATE DATABASE LINK	Not applicable	Not applicable
CREATE PROCEDURE	CREATE PROCEDURE	CREATE PROCEDURE
CREATE SEQUENCE	CREATE SEQUENCE	CREATE SEQUENCE
CREATE SESSION	CREATE EVENT SESSION	CREATE EVENT SESSION
CREATE SYNONYM	CREATE SYNONYM	CREATE SYNONYM
CREATE TABLE	CREATE TABLE	CREATE TABLE

Oracle Privileges	Microsoft SQL Server Privileges	IBM DB2 Privileges
CREATE TRIGGER	CREATE TRIGGER	CREATE TRIGGER
CREATE TYPE	CREATE TYPE	CREATE TYPE
CREATE VIEW	CREATE VIEW	CREATE VIEW

### Additional Privileges

The following privileges may be required depending on your specific configuration:

- DELETE ANY TABLE. Required to access the staging tables if you use the staging user for the delete from source step. If you cannot grant this privilege, you can do a direct delete grant on all application tables that are referenced in the metadata. Or, you can configure the source connection to use the application user for the delete from source step. If you use the application user, the application user needs access to the staging tables.
- SELECT ANY TABLE. Not required if the staging user has access to the application user tables. If you cannot grant this privilege, you can do direct select grants on all application tables that are referenced in the metadata.
- UPDATE ANY TABLE. If you cannot grant this privilege, you can do direct update grants on all application tables that are referenced in the metadata.
- EXECUTE ANY PROCEDURE. Required if the archive entities execute any procedures in the application user schema.
- ALTER ANY TRIGGER. Required if you use the staging user for the delete from source step.
- CREATE ANY TRIGGER. Required if you use the staging user for the delete from source step. If you cannot grant this privilege, then the staging user needs direct select privileges on the application tables instead. For example, grant select on ORDERS to amstage.
- EXECUTE ANY TYPE. Required to create staging tables with user defined types that are owned by a different user.

### Oracle Applications Privileges

To access Oracle applications, users must have insert privileges on the following tables:

- AP.AP\_HISTORY\_CHECKS\_ALL
- AP.AP\_HISTORY\_INV\_PAYMENTS\_ALL
- AP.AP\_HISTORY\_INVOICES\_ALL
- PO.PO\_HISTORY\_POS\_ALL
- PO.PO\_HISTORY\_RECEIPTS
- PO.PO\_HISTORY\_REQUISITIONS\_ALL

### Oracle Partition Exchange Privileges

If you configure the archive job to use Oracle partition exchange to delete source data, the staging user creates a table to identify the records to keep in the source. The archive job uses the partition in the table to swap the original source segment when the job deletes data from the source.

The following user privileges are required to use Oracle partition exchange to delete data from sources on Oracle databases:

- ALTER ANY TABLE

- DROP ANY TABLE
- ALTER USER QUOTA UNLIMITED

## History Read-Only User

The history read-only user has read-only access to all of the archive tables and resides on the target database. You can use the history read-only user to create the database link for seamless access.

The history read-only user requires the following user privileges:

Oracle Privileges	Microsoft SQL Server Privileges	IBM DB2 Privileges
ALTER SESSION	ALTER EVENT SESSION	ALTER SESSION
CREATE SESSION	CREATE EVENT SESSION	CREATE EVENT SESSION
SELECT ANY TABLE Or, grant table level permissions for all archive tables.	SELECT TABLE	

## History Application User

The history application user owns all of the archive tables and resides on the target database.

### Required Privileges

The following table lists the user privileges that the history application user requires:

Oracle Privileges	Microsoft SQL Server Privileges	IBM DB2 Privileges
ALTER SESSION	ALTER EVENT SESSION	ALTER SESSION
CREATE DATABASE LINK	Not applicable	Not applicable
CREATE PROCEDURE	CREATE PROCEDURE	CREATE PROCEDURE
CREATE SEQUENCE	CREATE SEQUENCE	CREATE SEQUENCE
CREATE SESSION	CREATE EVENT SESSION	CREATE EVENT SESSION
CREATE SYNONYM	CREATE SYNONYM	CREATE SYNONYM
CREATE TABLE	CREATE TABLE	CREATE TABLE
CREATE TRIGGER	CREATE TRIGGER	CREATE TRIGGER

Oracle Privileges	Microsoft SQL Server Privileges	IBM DB2 Privileges
CREATE TYPE	CREATE TYPE	CREATE TYPE
CREATE VIEW	CREATE VIEW	CREATE VIEW

### IBM DB2 Privileges

If you use the IBM DB2 load client utility or the import utility to insert data into the history database, then the history application user requires load and insert privileges.

### Restore Privileges

When you restore archived data, the history application user functions like the production application user during an archive cycle. To restore archived data, the history application user requires the SELECT ANY TABLE privilege.

## Combined User and Archive User for Seamless Access

The combined user and archive user have query-only access to archived data. The users are required for seamless access for combined and history data. The combined user has access to view both the current and history data. The archive user has access to view the history data.

For Oracle, PeopleSoft, and Siebel applications, create both users on the production database for performance reasons.

Both users require the following user privileges:

Oracle Privileges	Microsoft SQL Server Privileges	IBM DB2 Privileges
ALTER SESSION	ALTER EVENT SESSION	ALTER SESSION
CREATE CLUSTER	CREATE CLUSTER Use the Create Cluster wizard.	
CREATE DATABASE LINK	Not applicable	Not applicable
CREATE PROCEDURE	CREATE PROCEDURE	CREATE PROCEDURE
CREATE SEQUENCE	CREATE SEQUENCE	CREATE SEQUENCE
CREATE SESSION	CREATE EVENT SESSION	CREATE EVENT SESSION
CREATE SYNONYM	CREATE SYNONYM	CREATE SYNONYM
CREATE TABLE	CREATE TABLE	CREATE TABLE
CREATE TRIGGER	CREATE TRIGGER	
CREATE VIEW	CREATE VIEW	CREATE VIEW

Oracle Privileges	Microsoft SQL Server Privileges	IBM DB2 Privileges
EXECUTE ANY PROCEDURE	EXECUTE PROCEDURE	
SELECT ANY SEQUENCE	SELECT SEQUENCE	
SELECT ANY TABLE	Not applicable	
SELECT_CATALOG_ROLE	SELECT	
SELECT ANY DICTIONARY	Not applicable	

The following user privileges are required for Oracle applications:

- AQ\_ADMINISTRATOR\_ROLE
- CTXAPP
- HR\_REPORTING\_USER
- OLAP\_USER
- INSERT ANY TABLE (or specific to Oracle application tables where the report/form writes to the table)
- UPDATE ANY TABLE (or specific to Oracle application tables where the report/form writes to the table)
- DELETE ANY TABLE (or specific to Oracle application tables where the report/form writes to the table)

Use the following privileges to help improve Data Archive performance:

- CREATE ANY OUTLINE
- DROP ANY OUTLINE

## IBM DB2 Privileges

If you archive from an IBM DB2 source, set up privileges to bind the packages and to access data.

### Bind Packages Privileges

The user that you provide in the standalone job to bind IBM DB2 packages requires specific privileges.

The IBM DB2 Bind Package job requires an user ID as one of the parameters. The user that you provide runs the bind process on the source. Verify that the user has the required database access.

The following table lists the required authorizations for each platform:

Platform	Authorization
IBM DB2 for z/OS	The user requires one of the following privileges: <ul style="list-style-type: none"><li>- SYSADM</li><li>- SYSCTRL</li><li>- BINDADD and CREATE IN COLLECTION NULLID</li></ul>
IBM DB2 for Linux, UNIX, and Windows	DBADM
IBM DB2 for AS/400 iSeries	CHANGE authority or higher on the collection NULLID where the driver creates the packages.

## Login User Privileges

The user that you provide to connect or log in to IBM DB2 requires specific privileges to access data. You provide a login user when you define source and target connections and when you define connections to mine data in the Enterprise Data Manager.

When you define source and target connections for IBM DB2, you provide the user for the admin login, application login, and staging login names. All login names require the same privileges. When you define a connection to mine data in EDM, you provide the user to connect to IBM DB2.



The following table lists the privileges required for the user to connect to IBM DB2:

Platform	Privileges
IBM DB2 on z/OS	<p>The user requires SELECT access to the following system tables in the SYSIBM schema:</p> <ul style="list-style-type: none"> <li>- SYSTABLES</li> <li>- SYSCOLUMNS</li> <li>- SYSPROCEDURES</li> <li>- SYSPARMS</li> <li>- SYSCOLAUTH</li> <li>- SYSTABAUTH</li> <li>- SYSKEYS</li> <li>- SYSINDEXES</li> <li>- SYSSYNONYMS</li> <li>- SYSROUTINES</li> <li>- SYSFORIGNKEYS</li> <li>- SYSSCHEMAAUTH</li> </ul>
IBM DB2 on Linux, UNIX, or Windows	<p>The user requires SELECT access to the following system tables in the SYSCAT schema:</p> <ul style="list-style-type: none"> <li>- SYTABLES</li> <li>- COLUMNS</li> <li>- PROCEDURES</li> <li>- PROCPARMS</li> <li>- COLAUTH</li> <li>- TABAUTH</li> <li>- KEYCOLUSE</li> <li>- INDEXES</li> <li>- INDEXCOLUSE</li> <li>- REFERENCES</li> <li>- SCHEMATA</li> <li>- SCHEMAAUTH</li> <li>- ROLEAUTH (only for post Linux, UNIX, and Windows 95)</li> </ul>
IBM DB2 on AS400/i-Series	<p>The user requires SELECT access to the following system tables in the QSYS2 schema:</p> <ul style="list-style-type: none"> <li>- SYSTABLES</li> <li>- SYSCOLUMNS</li> <li>- SYSINDEXES</li> <li>- SYSCST</li> <li>- SYSKEYCST</li> <li>- SYSREFCST</li> <li>- SYSROUTINES</li> <li>- SYSPARMS</li> <li>- SYSFUNCS</li> <li>- SYSPROCS</li> <li>- SQLTABLEPRIVILEGES</li> </ul>

## SAP Application Retirement Privileges

To retire SAP applications, you need an SAP system user that includes remote function call (RFC) connection authorization.

For tables that store data in a readable format in the database layer, the retirement job uses the standard SAP database user to access data. The job accesses data directly from the database that hosts the SAP

system. The SAP database user includes all of the required authorizations to retire an SAP application. You do not need to create or edit a database user.

For tables that store data in a readable format in the application layer, the retirement job uses an SAP system user to log in to the SAP system and access data.

After you install Data Archive and install the SAP transports for application retirement, you assign a role to the SAP system user. The SAP transports include the ZINFA\_RETIREMENT\_PREPARATION role. The role includes the rest of the required authorizations. You specify the SAP system user in the source connection properties.

## ZINFA\_RETIREMENT\_PREPARATION Role

The ZINFA\_RETIREMENT\_PREPARATION role includes authorization to run the retirement job. The role is included in the Data Archive installation. You assign the role to the SAP system user that you plan to use to run the job.

The role includes the following authorization classes:

- AAAB (Cross-application authorization objects)
- BC\_A (Basis: Administration)

### AAAB Authorization Class

The authorizations in the AAAB authorization class allow the remote RFC user to run functions that prepare the database tables for retirement.

The following table lists the authorizations that the AAAB authorization class includes:

Authorization Object	Field	Values
S_RFC	ACTVT	16
S_RFC	RFC_NAME	*
S_RFC	RFC_TYPE	*

### BC\_A Authorization Class

The BC\_A authorization class includes the following authorization objects:

- S\_BTCH\_JOB. The authorizations allow Data Archive to create, run, and release retirement jobs in the SAP system.
- S\_C\_FUNCT. The authorizations allow retirement jobs to create folders in the file system to process attachments.
- S\_DATASET. The authorizations allow retirement jobs to read, write, and delete on the file system that contains the attachments.

The following table lists the authorizations that the BC\_A authorization class includes:

Authorization Object	Field	Values
S_BTCH_JOB	JOBACTION	DELE, PROT, RELE, SHOW
S_BTCH_JOB	JOBGROUP	*

Authorization Object	Field	Values
S_C_FUNCT	ACTVT	16
S_C_FUNCT	CFUNCNAME	*
S_C_FUNCT	PROGRAM	*
S_DATASET	ACTVT	06, 33, 34
S_DATASET	FILENAME	*
S_DATASET	PROGRAM	*

## APPENDIX B

# Data Visualization Designer Installation

Data Visualization Designer is a standalone application that you install on machines where users can create customized reports. The Designer application gives users advanced tools to design complex report layouts than the design tools available on the data visualization interface.

Reports developed on a user machine can be published to the Data Archive server.

## Data Visualization Designer System Requirements

You can install the Data Visualization Designer on separate user machines.

Verify the system requirements before you install the Data Visualization Designer application.

The following table lists the minimum system requirements for Data Visualization Designer:

Component	System Requirements
Operating System	You must have one of the following operating systems: <ul style="list-style-type: none"><li>- Windows</li><li>- UNIX</li><li>- Linux</li></ul>
CPU	Intel P4 Xeon 3.0 GHz
Memory	2 GB
Disk	1 GB free
JDK	Version 7 or above

## Installing Data Visualization Designer

Ensure there are no spaces in the names of the folders that lead to the `JReport.bat` file.

Any version of Data Visualization Designer prior to 6.4 HF2 is incompatible with the Data Archive 6.4 HF2 environment. You must use the latest version of Data Visualization Designer that is shipped with Data Archive 6.4 HF2.

1. Locate the `Designer.zip` file in the `$ILM_HOME/optional/` directory.
2. Extract the contents into the `$ILM_HOME/optional/` directory.  
The `Designer` folder contains the extracted contents of the `Designer.zip` file.
3. Locate the `JReport.bat` file in the `$ILM_HOME/optional/Designer/bin/` folder.  
If you are installing on a UNIX machine, locate the `JReport.sh` file in the `$ILM_HOME/optional/Designer/bin/` folder.
4. Create a shortcut to the `JReport.bat` or `JReport.sh` file.
5. Open the `JReport.bat` or `JReport.sh` file to launch Data Visualization Designer.

After you install the most recent version of Data Visualization Designer, complete the following tasks:

1. If you use the Internet Explorer or Google Chrome browsers, clear the browser cache.
2. Under **File > Preview**, select the **Run Linked Report** checkbox. This allows you to run linked reports from Data Visualization Designer.

**Note:** Prior to version 6.4 HF2, it was not mandatory to give a valid DATE pattern for the report parameter "DATE," due to a Designer bug. This bug has been fixed for Data Archive 6.4 HF2. Because of this fix, some reports might fail with a DATE validation exception. You must manually correct the DATE pattern and provide a valid pattern to resolve the issue.

# APPENDIX C

## Data Archive Installation Requirements Checklist and Architecture Options

This appendix includes the following topics:

- [Pre-Installation Requirements Overview, 134](#)
- [Archive to a Database Checklists, 135](#)
- [Archive or Retire to Data Vault Checklists, 138](#)
- [Data Archive Options Installation Checklist, 146](#)
- [Data Archive Architecture Recommendations, 146](#)

### Pre-Installation Requirements Overview

Before you install Data Archive, verify that machines that host Data Archive meet the system and disk space requirements necessary to support Data Archive.

The system and disk space requirements depend on how you will use Data Archive and how much data you plan to archive.

Use the checklists in this appendix to identify the prerequisites for the Data Archive installation. The checklists are organized by the following business needs:

- Archive to a database
- Retire or archive to the Data Vault

This appendix also includes the recommended Data Archive architecture options to help you determine the appropriate architecture for your data center.

**Note:** For information about the databases and operating systems supported by Data Archive, see the *Data Archive Product Availability Matrix* located on [My Support](#).

# Archive to a Database Checklists

If you plan to archive data to a database, you must install the ILM repository and the ILM Engine. Optionally, you can configure seamless access.

Use the checklists to verify the pre-installation requirements for the following Data Archive components:

- Data Archive installer
- ILM repository
- ILM Engine
- Data Archive user interface

## Data Archive Installer Prerequisites

Before you run the Data Archive installer, perform the following tasks:

- Get the standard license key.
- Get an application license key based on your enterprise application.
- If you plan to install Data Archive in graphical mode on UNIX, install and configure an X Windows System.
- Get source information required by the installer to create a connection to the source application.

## Information Required for Connecting to the Source Application

To create a connection to the source application, you must enter information about the source application and the data store it uses.

The following table provides space to enter information about the data store for the source application:

Data Store for Source Application	Enter Information
Server Platform	
Operating System Release Level	
Security Software (For example, RACF)	
Communication Protocol	
DBMS	
DBMS Version	

The following table provides space to enter information about the source application:

Source Application Details	Enter Information
Vendor	
Release/Version	

Source Application Details	Enter Information
Platform	
Operating System Release Level	

## ILM Repository Requirements Checklist

Verify that the database meets the requirements for the ILM repository.

### Database management system

Verify that the machine that will host the ILM repository has one of the following database management systems:

- Oracle 11g
- Oracle 12c
- IBM DB2 9.7
- IBM DB2 9.8
- IBM DB2 10.1
- Microsoft SQL Server 2008
- Microsoft SQL Server 2012
- Microsoft SQL Server 2014

### ILM repository database user and tablespaces

You can create the ILM repository before you install or you can let the installer create it.

**Note:** If the database management system is IBM DB2, you must create the ILM repository before you install.

If you create the ILM repository before you install Data Archive, perform the following tasks:

- Create the ILM repository database user.
- Create the following ILM repository tablespaces:
  - AM\_DATA tablespace with a minimum of 3 GB space
  - AM\_INDEX tablespace with a minimum of 3 GB space
  - Rollback tablespace with a minimum of 1 GB space
  - Temporary tablespace with a minimum of 2 GB space
- Set the ILM tablespaces page size and buffer pool page size to at least 32 KB.
- Set the temporary tablespace page size and buffer pool page size to at least 32 KB.
- Grant the ILM repository database user access to the ILM repository schema, tablespaces, and catalog tables.
- Grant the ILM repository database user database privileges.



## Security

- Get the SYSTEM password. Optional if your database administrator can enter the password.
- If the database management system is Microsoft SQL Server, assign the SYSADMIN role to the administrator.

## ILM Engine Requirements

Verify that the machine allocated to host the ILM Engine meets the system and software requirements.

### Server Configuration

Verify that the machine has the following configuration:

- At minimum, a dual core processor.
- A minimum of 4 GB of RAM.
- A minimum of 2 GB heap space memory.
- The server port number is unique and higher than 1024.

### Operating system

The operating system on the machine that hosts the ILM Engine depends on the database management system of the ILM repository.

If the ILM repository is on an Oracle or an IBM DB2 database, verify that the machine has one of the following operating systems:

- 32-bit Red Hat Linux 6.1, 6.2 and higher with a x86 chip set
- 64-bit Red Hat Linux 6.1, 6.2 and higher with a x64 or IBM zSeries chip set
- 32-bit SUSE Linux ES10 or ES11 with a x86 chip set
- 64-bit SUSE Linux ES10 or ES11 with a x64 or IBM zSeries chip set
- 32-bit Windows 2008 with a x86 chip set
- 64-bit Windows 2008 with a x64 chip set
- 64-bit Windows 2008 R2 with a x64 chip set
- 64-bit Windows 2012 with a x64 chip set

If the ILM repository is on a Microsoft SQL Server database, verify that the machine has one of the following operating systems:

- 32-bit Windows 2008 with a x86 chip set
- 64-bit Windows 2008 with a x64 chip set
- 64-bit Windows 2008 R2 with a x64 chip set
- 64-bit Windows 2012 with a x64 chip set

### Font

- Install the Arial Unicode Microsoft font.  
Data Archive requires this font to generate reports and support non-Roman alphabets. The file name of the font is `ARIALUNI.TTF`.

### Security

- Verify that the user that runs the Data Archive installer has read and write privileges to the installation directory.

## Client Machine Requirements

Verify that the machines from which users access Data Archive meet the requirements.

### Operating System

Verify that the client machine has one of the following 32-bit Windows operating systems:

- Windows 7
- Vista Business or Enterprise SP1
- XP Pro SP2
- Windows 2008
- Windows 2003

### Browser

Verify that the client machine has one of the following browsers:

- Internet Explorer 8.0 or 9.0
- Google Chrome 30.x

Verify that the browser has the following settings:

- Javascript enabled
- Popup windows allowed

### Java

- Install Java Development Kit (JDK) SE 8.

### Other

- Verify that the client machine is connected to the network.

## ILM Discovery Option

If you have the ILM Discovery option, you can run profiles and discover table relationships for source data or data you archived to the Data Vault. Install or upgrade to Informatica 9.6.0.

For information about prerequisites and installation, see the *Informatica Data Quality 9.6.0 Installation and Configuration Guide*.

## Archive or Retire to Data Vault Checklists

If you plan to archive or retire data to the Data Vault, you must install the ILM repository, the ILM Engine, and the Data Vault components. Additionally, you can install Data Visualization Designer to create reports based on archived data.

Use the checklists to verify the pre-installation requirements for the following Data Archive components:

- Data Archive installer
- ILM repository
- ILM Engine
- Data Vault
- Data Archive user interface

## Data Archive Installer Prerequisites

Before you run the Data Archive installer, perform the following tasks:

- Get the standard license key.
- Get the advanced license key if you require Data Visualization.
- Get an application license key based on your enterprise application.
- If you plan to install Data Archive in graphical mode on UNIX, install and configure an X Windows System.
- Get source information required by the installer to create a connection to the source application.

## Information Required for Connecting to the Source Application

To create a connection to the source application, you must enter information about the source application and the data store it uses.

The following table provides space to enter information about the data store for the source application:

Data Store for Source Application	Enter Information
Server Platform	
Operating System Release Level	
Security Software (For example, RACF)	
Communication Protocol	
DBMS	
DBMS Version	

The following table provides space to enter information about the source application:

Source Application Details	Enter Information
Vendor	
Release/Version	

Source Application Details	Enter Information
Platform	
Operating System Release Level	

## ILM Repository Requirements Checklist

Verify that the database meets the requirements for the ILM repository.

### Database management system

Verify that the machine that will host the ILM repository has one of the following database management systems:

- Oracle 11g
- Oracle 12c
- IBM DB2 9.7
- IBM DB2 9.8
- IBM DB2 10.1
- Microsoft SQL Server 2008
- Microsoft SQL Server 2012
- Microsoft SQL Server 2014

### ILM repository database user and tablespaces

You can create the ILM repository before you install or you can let the installer create it.

**Note:** If the database management system is IBM DB2, you must create the ILM repository before you install.

If you create the ILM repository before you install Data Archive, perform the following tasks:

- Create the ILM repository database user.
- Create the following ILM repository tablespaces:
  - AM\_DATA tablespace with a minimum of 3 GB space
  - AM\_INDEX tablespace with a minimum of 3 GB space
  - Rollback tablespace with a minimum of 1 GB space
  - Temporary tablespace with a minimum of 2 GB space
- Set the ILM tablespaces page size and buffer pool page size to at least 32 KB.
- Set the temporary tablespace page size and buffer pool page size to at least 32 KB.
- Grant the ILM repository database user access to the ILM repository schema, tablespaces, and catalog tables.
- Grant the ILM repository database user database privileges.

## Security

- Get the SYSTEM password. Optional if your database administrator can enter the password.
- If the database management system is Microsoft SQL Server, assign the SYSADMIN role to the administrator.

## ILM Engine Requirements

Verify that the machine allocated to host the ILM Engine meets the system and software requirements.

### Server configuration

Verify that the machine has the following configuration:

- At minimum, a dual core processor.
- A minimum of 4 GB of RAM.
  - Note:** If you install Data Vault Service on the same machine that hosts the ILM Engine, then the machine must have a minimum of 12 GB of RAM.
- A minimum of 2 GB heap space memory.
- The server port number is unique and higher than 1024.
- The staging folder size is equal to 50% the size of the data that you plan to archive in a single job.

### Operating system

The operating system on the machine that hosts the ILM Engine depends on the database management system of the ILM repository.

If the ILM repository is on an Oracle or an IBM DB2 database, verify that the machine has one of the following operating systems:

- 32-bit Red Hat Linux 5, 6.1, 6.2 and above with a x86 chip set
- 64-bit Red Hat Linux 5, 6.1, 6.2 and above with a x64 or IBM zSeries chip set
- 32-bit SUSE Linux ES10 or ES11 with a x86 chip set
- 64-bit SUSE Linux ES10 or ES11 with a x64 or IBM zSeries chip set
- 32-bit Windows 2008 with a x86 chip set
- 64-bit Windows 2008 with a x64 chip set
- 64-bit Windows 2008 R2 with a x64 chip set
- 64-bit Windows 2012 with a x64 chip set

If the ILM repository is on a Microsoft SQL Server database, verify that the machine has one of the following operating systems:

- 32-bit Windows 2008 with a x86 chip set
- 64-bit Windows 2008 with a x64 chip set
- 64-bit Windows 2008 R2 with a x64 chip set
- 64-bit Windows 2012 with a x64 chip set

## Java

Install the following Java version:

- If you plan to install Data Visualization, install the 64-bit Java Development Kit (JDK) SE 8.
- If you do not plan to install Data Visualization, install the 64-bit Java Runtime Environment (JRE) SE 8.

## Font

- Install the Arial Unicode Microsoft font.  
Data Archive requires this font to generate reports and support non-Roman alphabets. The file name of the font is `ARIALUNI.TTF`.

## Security

- Verify that the user that runs the Data Archive installer has read and write privileges to the installation directory.

# Data Vault Requirements

When you install Data Vault, you install the following components:

### Data Vault Service

Includes the Data Vault Agent and the Data Vault ODBC driver. You can install the Data Vault Service on the same machine as the ILM Engine.

### Data Vault Data Archive Plug-in

You must install the Data Vault Data Archive plug-in on the same machine as the ILM Engine.

### Data Vault Administration Tool and SQL Tool

You must install the Data Vault Administration Tool and SQL Tool on a machine with a Windows operating system.

Verify that the machine allocated to host the Data Vault Service meets the system and software requirements.

### Server configuration

Verify that the machine has the following configuration:

- A 64-bit server.
- At minimum, four core processors.
- A minimum of 8 GB of RAM.  
**Note:** If you install Data Vault Service on the same machine that hosts the ILM Engine, then the machine must have a minimum of 12 GB of RAM.
- A minimum of 20 GB of local storage.
- A shared folder, visible to all servers running Data Vault agents, with a size that is equal to 50% of the size of the data that you plan to archive to Data Vault (up to a maximum shared folder size of 500 GB).
- The final storage space is equal to 10%-15% of the table data that you plan to archive.  
**Note:** Final storage space can be local or external. External storage options include Hadoop HDFS, NetApp, EMC Centera, EMC Atmos, EMC Data Domain, Hitachi HCP, Storage Area Network (SAN), Network Attached Storage (NAS), Content Addressed Storage (CAS), and DAS.

For guidelines about server sizes for live archive, see [“Server Guidelines for Archive to Data Vault” on page 143](#).

For guidelines about server sizes for application retirement, see [“Server Guidelines for Retire to Data Vault” on page 144](#).

### Operating system

If you plan to archive or retire data to NAS, use one of the following operating systems:

- 64-bit Red Hat Linux 5, 6.1, 6.2 and later with a x64 chip set
- 64-bit SUSE Linux ES10 or ES11 with a x64 chip set
- 64-bit Windows 2008, 2008 R2, or 2012 with a x64 chip set

**Note:** If you plan to archive or retire data to a target other than NAS, see the product matrix availability for the supported operating systems at <https://kb.informatica.com>.

### System-specific notes

The following limitations apply to the Windows 2012 with the AMD Opteron chip set system:

- Informatica supports the NTFS file system.
- If you install Data Vault on Windows, you must install Microsoft Visual C++ Redistributable Package (x64) Service Pack 1.

To download Microsoft Visual C++ Redistributable Package (x64) Service Pack 1, go to <http://www.microsoft.com/downloads/en/details.aspx?familyid=ba9257ca-337f-4b40-8c14-157cfdffee4e&displaylang=en>

### Java

Install the 64-bit version of Java Development Kit (JDK) SE 8.

## Server Guidelines for Archive to Data Vault

The size of the server that hosts Data Vault depends on the number and size of applications you plan to archive to Data Vault. Server size also depends on the amount of data you plan to archive at a time on a regular basis.

The following table lists server size and processor guidelines for the machine that hosts Data Vault:

Number of Applications	Average Database Size of an Application	Percentage of Data for Archive	Growth Rate of Data	Recommended Processor	Recommended RAM	Recommended Server Storage
1	2 TB	30%	30%	12 cores	32 GB	0.24 TB
3	1.5 TB	30%	30%	18 cores	64 GB	1.62 TB
20	2 TB	50%	30%	24 cores	96 GB	14.4.8 TB

**Note:** If you plan to archive data from more than 20 applications, contact Informatica Global Customer Support for server guidelines.

## Server Guidelines for Retire to Data Vault

The size of the server that hosts Data Vault depends on the number and size of applications you plan to retire to Data Vault.

The following table lists server size and processor guidelines for the machine that hosts Data Vault:

Number of Applications	Average Database Size of an Application	Recommended Processor	Recommended RAM	Recommended Server Storage
5	200 to 500 GB	10 cores	32 GB	0.4 TB
20	200 to 500 GB	12 cores	32 GB	2 TB
40	200 to 500 GB	20 cores	64 GB	8 TB

**Note:** If you plan to retire more than 40 applications, contact Informatica Global Customer Support for server guidelines.

## Client Machine Requirements

Verify that the machines from which users access Data Archive meet the requirements.

### Operating System

Verify that the client machine has one of the following 32-bit Windows operating systems:

- Windows 7
- Vista Business or Enterprise SP1
- XP Pro SP2
- Windows 2008
- Windows 2003

### Browser

Verify that the client machine has one of the following browsers:

- Internet Explorer 8.0 or 9.0
- Google Chrome 30.x

Verify that the browser has the following settings:

- Javascript enabled
- Popup windows allowed

### Java

- Install Java Development Kit (JDK) SE 8.

### Other

- Verify that the client machine is connected to the network.



## Data Validation Option

If you choose to install Data Validation Option, use this checklist to verify the prerequisites to install Data Validation Option.

### Server Configuration

Verify that the machine on which you install Data Validation Option has the following configuration:

- A minimum of 1 GB of RAM.
- A minimum of 256 MB disk space.

### Permissions

You must have permissions on the Data Validation Option Client machine to perform the following tasks:

- Create and modify environment variables on the Data Validation Option Client machine.
- Read from and write to the Data Validation Option installation directory and subdirectories.

### PowerCenter Requirements

- PowerCenter must be installed on the same network as the Data Validation Option client machine.
- The PowerCenter version must be at least 8.6.1 HotFix 10.
- Install a later version of PowerCenter if you implement the following Data Validation Option features.
  - Informatica authentication. Requires PowerCenter 9.1.0 HotFix 3 or later,
  - SAP R/3 data source. Requires PowerCenter 9.1.0 or later.
  - SAS data source. Requires PowerCenter 9.1.0 or later.

### Preinstallation Tasks

- Replace the existing IBM DB2 driver with the IBM DB2 10.1 driver if you want to create the Data Validation Option repository on IBM DB2 10.1.
- Create the Data Validation Option repository database.
- Verify the code page compatibility.
- Install the PowerCenter Client.
- Gather the PowerCenter information required for Data Validation Option installation.
- Configure the associated PowerCenter user.
- Optionally, prepare to run DVOCmd on a UNIX machine.

## ILM Discovery Option

If you have the ILM Discovery option, you can run profiles and discover table relationships for source data or data you archived to the Data Vault. Install or upgrade to Informatica 9.6.0.

For information about prerequisites and installation, see the *Informatica Data Quality 9.6.0 Installation and Configuration Guide*.

# Data Archive Options Installation Checklist

If you plan to archive SAP data or retire the SAP application, complete the following tasks after you install Data Archive.

## SAP Retirement Installation Checklist

- Install the SAP Java Connector.
  - Download the SAP Java Connector 3.0.12 or later from the SAP Marketplace: <http://service.sap.com/connectors>
  - Choose the installation file based on the operating system of the server that hosts the ILM Engine. For example, the SAP system is on Windows and Data Archive is on Linux. Choose the Linux version.
  - Install the SAP Java Connector on the same machine that hosts the ILM Engine.
- Install the SAP transports to the SAP application that you want to retire.
  - Access the SAP transports in the following Data Archive directory:  
`<Data Archive Installation>\optional\SAP_retirement_transports.zip`
- Get the following SAP user credentials:
  - User ID
  - Password
  - Client
  - Language
- Assign the user that runs the retirement job to the ZINFA\_RETIREMENT\_PREPARATION role.
  - The user must be able to access the RFC connection.
  - The SAP transport includes the ZINFA\_RETIREMENT\_PREPARATION role.
- Set the value of the SAP retirement properties in the `conf.properties` file.
  - Set the values of the `informia.bcp.columnSeparator` and `informia.bcp.rowSeparator` properties to unique values that are not in the SAP table data. For example, use the values `^#^` or `@#@#`.

## Data Archive Architecture Recommendations

Refer to the recommendations in this section to determine the best architecture for your data center.

## Component Diagram for Data Vault

The following image shows the major components of Data Archive. Each component has its specific installation requirements.

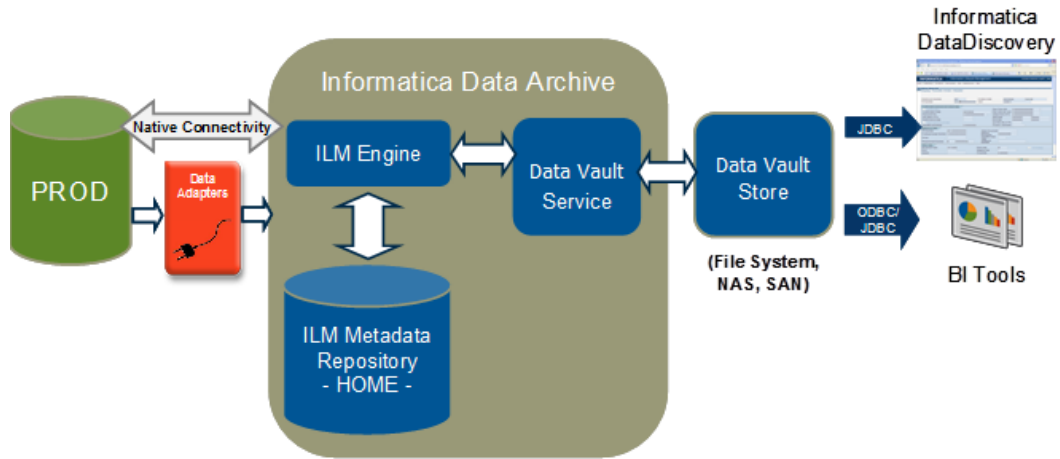

## ILM Engine and Informatica Data Vault

The following image shows the recommended architecture for the ILM Engine and Data Vault:

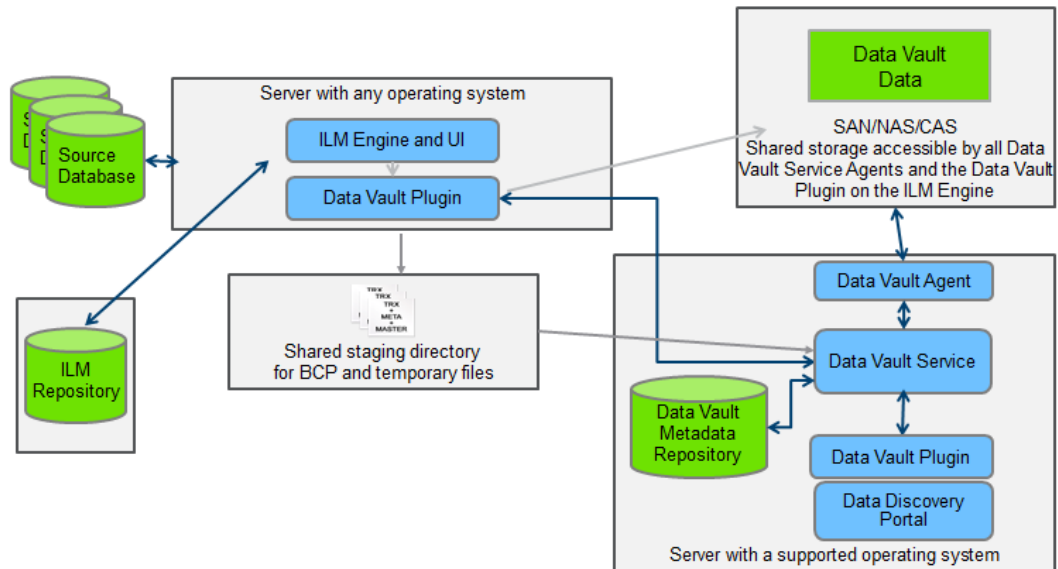

## Data Vault Architecture with Data Validation Option

The following image shows the recommended architecture for Data Vault with the data validation option:

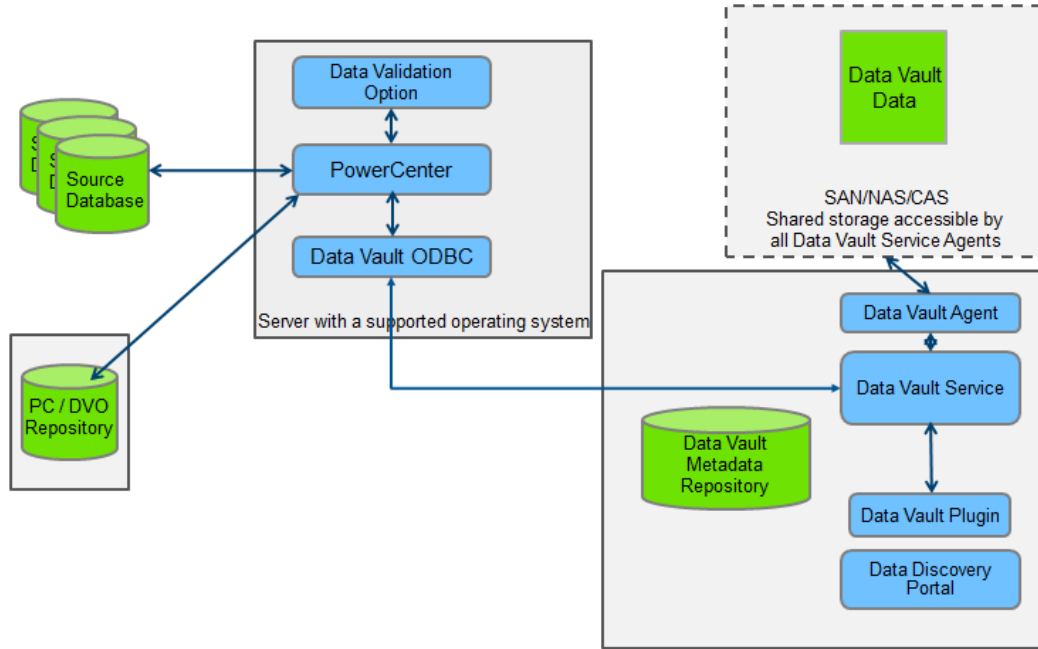

## Data Vault Architecture with the Federation and Visualization Option

The following image shows the recommended architecture for Data Vault with the federation and data visualization options:

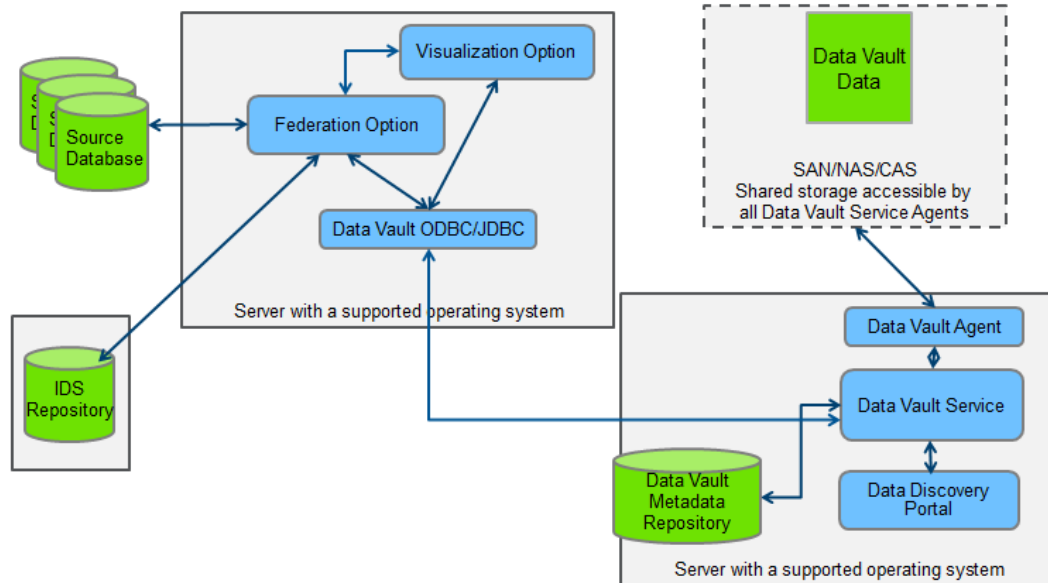

## Data Vault Architecture for Scaling Agents on Multiple Nodes

The following image shows the recommended architecture for Data Vault if you scale Data Vault query agents on multiple nodes:

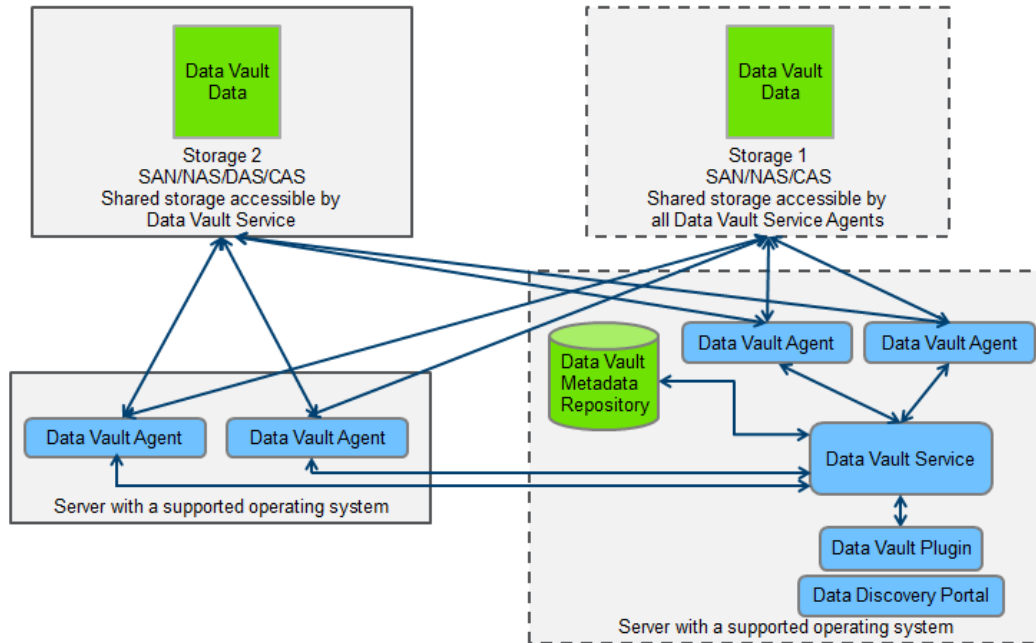

## Data Vault Configuration for High Availability

The following image shows the recommended architecture for Data Vault high availability:

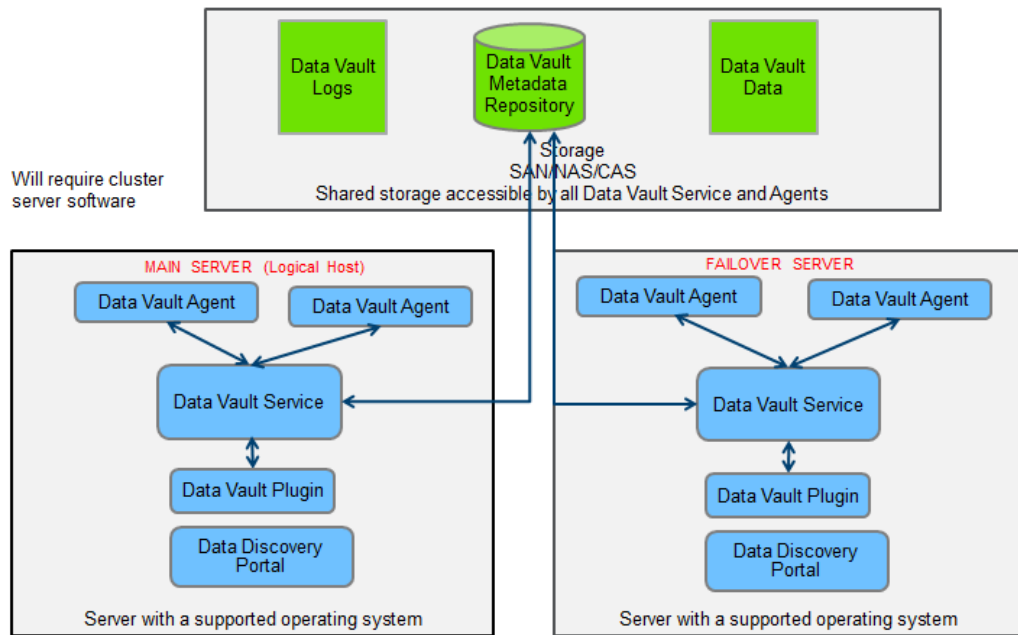

# Active-Passive Data Vault Server with Active-Active Data Vault Query

The following image shows the recommended architecture for Data Vault with an active-passive server and active-active query:

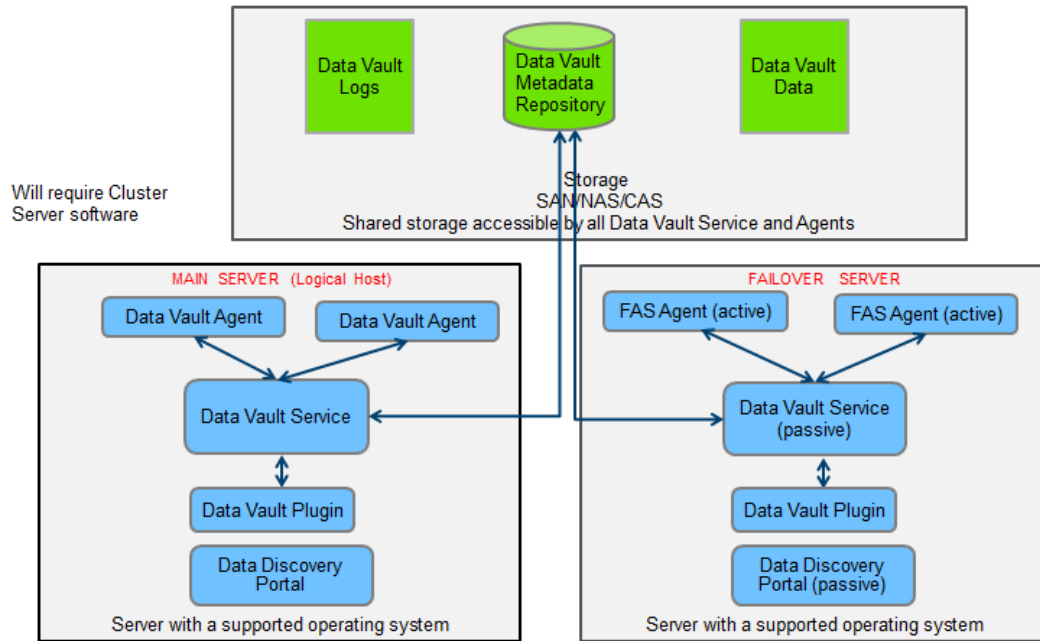

## Data Archive Repositories

The following image shows the Data Archive repositories on a server:

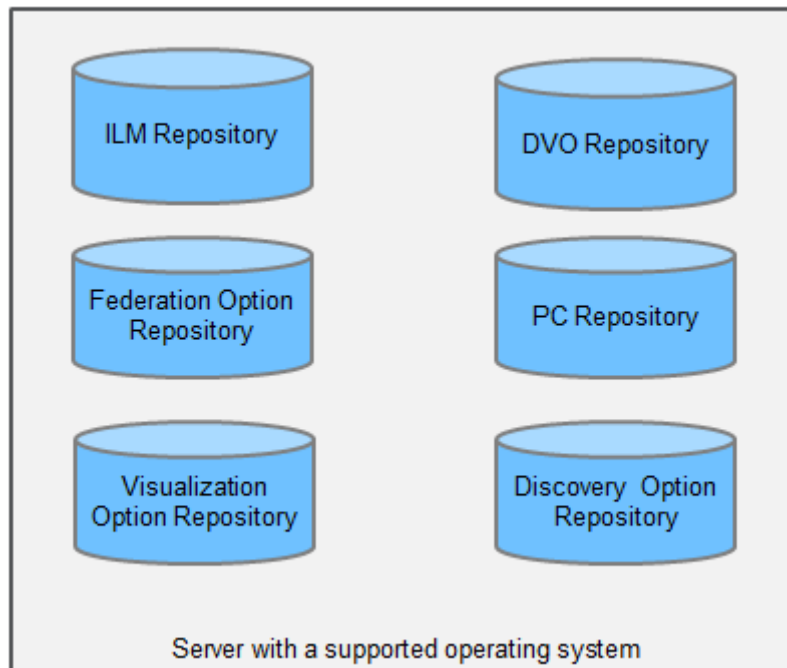

# INDEX

## A

- accelerators
  - installation [15, 64](#)
- administration user
  - privileges [121](#)
- AGENT\_CMD
  - ssa.ini [77](#)
- AGENT\_CONTROL
  - ssa.ini [77](#)
- AGENT\_COUNT
  - ssa.ini [77](#)
- application retirement
  - SAP [113, 115](#)
- Archive Service
  - Windows service registration [81](#)
- archive to Data Vault
  - installation [14](#)
- archive to database
  - installation [14](#)
- archive user
  - privileges [126](#)
- Arial Unicode MS font
  - requirements [20](#)
- attachments
  - SAP applications [113](#)

## B

- browsers
  - configuration [75](#)

## C

- combined user
  - privileges [126](#)
- components
  - Data Archive [26](#)
- connection details
  - ILM repository [26](#)
- console mode
  - Data Vault installation [51](#)
  - Data Vault upgrade [91](#)
  - installation [33](#)
- Curl requirements
  - Data Vault [22](#)

## D

- Data Archive
  - components [26](#)
  - requirements [17, 20](#)

- Data Discovery
  - installation [26](#)
- Data Masking
  - requirements [17, 20](#)
  - upgrade [83](#)
- Data Subset
  - requirements [17, 20](#)
  - upgrade [83](#)
- Data Vault
  - Curl requirements [22](#)
  - installation [13, 43](#)
  - Java requirements [22](#)
  - requirements [21](#)
  - space requirements [23](#)
  - ssa\_starter [76](#)
  - startup [76](#)
  - system requirements [21](#)
  - uninstallation [111](#)
  - upgrade [88](#)
- Data Vault Administration Tool
  - installation [50](#)
  - uninstallation [111](#)
  - upgrade [88](#)
- Data Vault Agent
  - installation [47, 54](#)
  - startup [79](#)
  - uninstallation [111](#)
  - upgrade [88](#)
- Data Vault Data Archive Plug-in
  - installation [50, 56](#)
  - uninstallation [111](#)
  - upgrade [88](#)
- Data Vault Loader
  - installation [26](#)
- Data Vault ODBC driver
  - installation [49, 55, 97, 98](#)
  - uninstallation [111](#)
  - upgrade [88](#)
- Data Vault Service
  - installation [43, 51](#)
  - startup [79](#)
  - uninstallation [111](#)
- Data Vault Service for External Attachments
  - installation [32](#)
  - Windows service registration [81](#)
- Data Vault SQL Tool
  - installation [50](#)
  - uninstallation [111](#)
  - upgrade [88](#)
- data visualization
  - installation [26](#)
- database requirements
  - source [104](#)
  - target [106](#)
- database users
  - ILM repository [26](#)



## E

EXE  
ssa.ini [77](#)

## F

filegroups  
ILM repository [26](#)  
font  
requirements [20](#)

## G

graphical mode  
Data Vault installation [43](#)  
Data Vault upgrade [90](#)  
installation [25](#), [26](#)

## H

hardware requirements  
ILM Engine [20](#)  
healthcare accelerators  
installation [67](#)  
heap space  
requirements [20](#)  
history application user  
privileges [125](#)  
history read-only user  
privileges [125](#)  
history tablespaces  
targets [106](#)  
hotfixes  
ILM products [24](#)

## I

IBM DB2  
privileges [127](#)  
ILM application server  
starting and stopping [76](#)  
ILM Engine  
requirements [20](#)  
ILM product  
logging in [76](#)  
ILM products  
hotfixes [24](#)  
installation [25](#)  
installation of [24](#)  
upgrade of [24](#), [83](#)  
ILM repository  
connection details [26](#)  
creating [26](#)  
database users [26](#)  
filegroups [26](#)  
requirements [17](#)  
installation  
accelerators [15](#), [25](#), [64](#)  
archive to Data Vault [14](#)  
archive to database [14](#)  
components [12](#), [13](#)  
console mode [33](#)  
Data Discovery [26](#)

installation (*continued*)

Data Vault [13](#), [43](#)  
Data Vault Administration Tool [50](#)  
Data Vault Agent [47](#), [54](#)  
Data Vault Data Archive Plug-in [50](#), [56](#)  
Data Vault Loader [26](#)  
Data Vault ODBC driver [49](#), [55](#), [97](#), [98](#)  
Data Vault Service [43](#), [51](#)  
Data Vault Service for External Attachments [32](#)  
Data Vault SQL Tool [50](#)  
data visualization [26](#)  
graphical mode [25](#), [26](#), [43](#)  
healthcare accelerators [67](#)  
ILM products [24](#), [25](#)  
license keys for [17](#)  
overview [12](#), [13](#)  
SAP Java Connector [116](#)  
silent mode [38](#)  
zip files [25](#)  
interim tables  
staging tablespace sizes [105](#)

## J

Java requirements  
Data Vault [22](#)  
Java Runtime Environment  
supported version [20](#)  
JavaScript  
support [75](#)

## L

license keys  
installation [17](#)  
Linux  
installation on [25](#)  
live archiving  
requirements [105](#)  
LOGDIR  
ssa.ini [77](#)

## M

META  
ssa.ini [79](#)  
Microsoft Internet Explorer  
supported version [75](#)  
Mozilla Firefox  
supported version [75](#)

## O

Oracle  
partition exchange [105](#), [123](#)

## P

partition exchange  
privileges [123](#)  
requirements [105](#)  
port  
requirements [20](#)

- privileges
  - administration user [121](#)
  - archive user [126](#)
  - combined user [126](#)
  - history application user [125](#)
  - history read-only user [125](#)
  - IBM DB2 [127](#)
  - production application user [123](#)
  - SAP application retirement [129](#)
  - staging user [123](#)
- processors
  - requirements [20](#)
- production application user
  - privileges [123](#)

## R

- RAM
  - requirements [20](#)
- requirements
  - Data Vault [21](#)
  - font [20](#)
  - heap space [20](#)
  - ILM Engine [20](#)
  - ILM repository [17](#)
  - live archiving [105](#)
  - partition exchange [105](#)
  - processors [20](#)
  - RAM [20](#)
  - SAP application retirement [105](#)
- retirement
  - SAP applications [113](#)
- roles
  - SAP application retirement [117](#)

## S

- Safari
  - supported version [75](#)
- SAP application retirement
  - conf.properties file properties [117](#)
  - FTP connection [117](#)
  - NFS mount [117](#)
  - privileges [129](#)
  - projects [113](#)
  - requirements [105](#)
  - roles [117](#)
  - setup [115](#)
  - transports [116](#)
- SAP applications
  - attachments in [113](#)
- SAP Java Connector
  - installation [116](#)
- SAP transports
  - application retirement [116](#)
- seamless data access
  - users [126](#)
- SERVER\_CMD
  - ssa.ini [77](#)
- SERVER\_CONTROL
  - ssa.ini [77](#)
- services
  - archive [81](#)
  - Data Vault Service for External Attachments [81](#)
  - Windows [81](#)

- silent mode
  - Data Vault installation [57](#)
  - Data Vault upgrade [91](#)
  - installation [38](#)
- sources
  - database requirements [104](#)
- ssa\_starter
  - Data Vault [76](#)
  - options [77](#)
  - syntax [77](#)
- ssa.ini
  - AGENT\_CMD [77](#)
  - AGENT\_CONTROL [77](#)
  - AGENT\_COUNT [77](#)
  - EXE [77](#)
  - LOGDIR [77](#)
  - META [79](#)
  - SERVER\_CMD [77](#)
  - SERVER\_CONTROL [77](#)
  - STARTER [77](#)
  - USER [77](#)
  - VERBOSE [77](#)
- ssaagent
  - startup [79](#)
- ssaserver
  - startup [79](#)
- staging tables
  - staging tablespace sizes [105](#)
- staging tablespaces
  - live archiving [105](#)
- staging user
  - privileges [123](#)
- startApplimation
  - files and scripts [76](#)
- STARTER
  - ssa.ini [77](#)
- startup
  - Data Vault [76](#)
- stopApplimation
  - files and scripts [76](#)
- syntax
  - ssa\_starter [77](#)
- system requirements
  - Data Vault [21](#)

## T

- tablespaces
  - history [106](#)
  - ILM repository [26](#)
- targets
  - database requirements [106](#)

## U

- uninstallation
  - Data Vault [111](#)
- UNIX
  - installation on [25](#)
- upgrade
  - Data Vault [88](#)
- upgrades
  - ILM products [24](#), [83](#)
- USER
  - ssa.ini [77](#)

## users

- administration [121](#)
- archive, seamless access [126](#)
- combined, seamless access [126](#)
- history application [125](#)
- history read-only [125](#)
- ILM repository [26](#)
- ILM Repository user [19](#)
- production application [123](#)
- staging [123](#)

## V

- VERBOSE
- ssa.ini [77](#)

## W

- web browsers
  - configuration [75](#)
- Windows
  - installation on [25](#)
  - services [81](#)

## Z

- ZINFA\_RETIREMENT\_PREPARATION
  - SAP application retirement role [117](#)
- zip files
  - installation [25](#)